

Wireless World

Radio • Electronics • Electro-Acoustics

34th YEAR OF PUBLICATION

FEBRUARY 1945

Proprietors :
ILIFFE & SONS LTD.

Managing Editor :
HUGH S. POCOCK,
M.I.E.E.

Editor :
H. F. SMITH

Editorial, Advertising
and Publishing Offices:
DORSET HOUSE,
STAMFORD STREET,
LONDON, S.E.1.

Telephone :
Waterloo 3333 (35 lines).
Telegrams :
"Ethaworld, Sedist, London."



**PUBLISHED
MONTHLY**

Price : 1/6

(Publication date 26th
of preceding month)

Subscription Rate :
Home and Abroad
20/- per annum.

MONTHLY COMMENTARY	33
RADIOLOCATION By Dr. R. L. Smith-Rose	34
NEW DUTCH VALVES	38
AIRCRAFT DF EQUIPMENT 2. The "Marconator" By Charles B. Bovill	39
WAVE TRAPS By S. W. Amos	43
TELEVISION SOUND	48
MECHANISM OF RADIO FADE-OUTS	49
WORLD OF WIRELESS	50
NEWS IN ENGLISH FROM ABROAD	52
RADIO ENGINEERING EDUCATION By Thomas Roddam	53
SINGLE-VALVE MODULATED TEST OSCILLATOR By K. W. Mitchell	56
LETTERS TO THE EDITOR	58
RANDOM RADIATIONS By "Diallist"	60
RECENT INVENTIONS	62
UNBIASED. By Free Grid	64

Branch Offices :

COVENTRY :
8-10, Corporation Street,
Telephone : Coventry 5210.
Telegrams :
"Autocar, Coventry."

BIRMINGHAM :
Guildhall Buildings,
Navigation Street, 2.
Telephone :
Midland 2971 (5 lines).
Telegrams :
"Autopress, Birmingham."

MANCHESTER :
260, Deansgate, 3.
Telephone :
Blackfriars 4412 (4 lines).
Telegrams :
"Iliffe, Manchester."

GLASGOW :
26B, Renfield Street, C.2.
Telephone : Central 4857.
Telegrams : "Iliffe, Glasgow."



As many of the circuits and apparatus described in these pages are covered by patents, readers are advised, before making use of them, to satisfy themselves that they would not be infringing patents.

"HYPERLOY"

TRANSFORMERS AND CHOKES

A range of High-performance, space-saving Components designed to meet the most exacting requirements of modern Electronic and Communications equipments.

- Small in size
- Weighing only 2 oz.
- Meeting the most rigid Tropical Specification
- Easily mounted in any position
- Manufactured in a variety of windings to meet many diverse applications

★ Owing to wartime restrictions on supply of raw materials, it is not possible to supply Wearite Components for purposes other than those connected directly with the war effort.

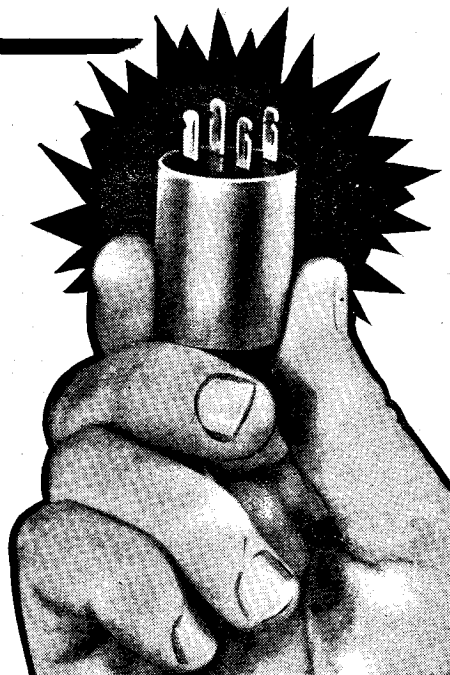

WRIGHT & WEAIRE, LIMITED

HIGH ROAD, TOTTENHAM, LONDON, N.17 — Telephone: TOTtenham 3847-8-9

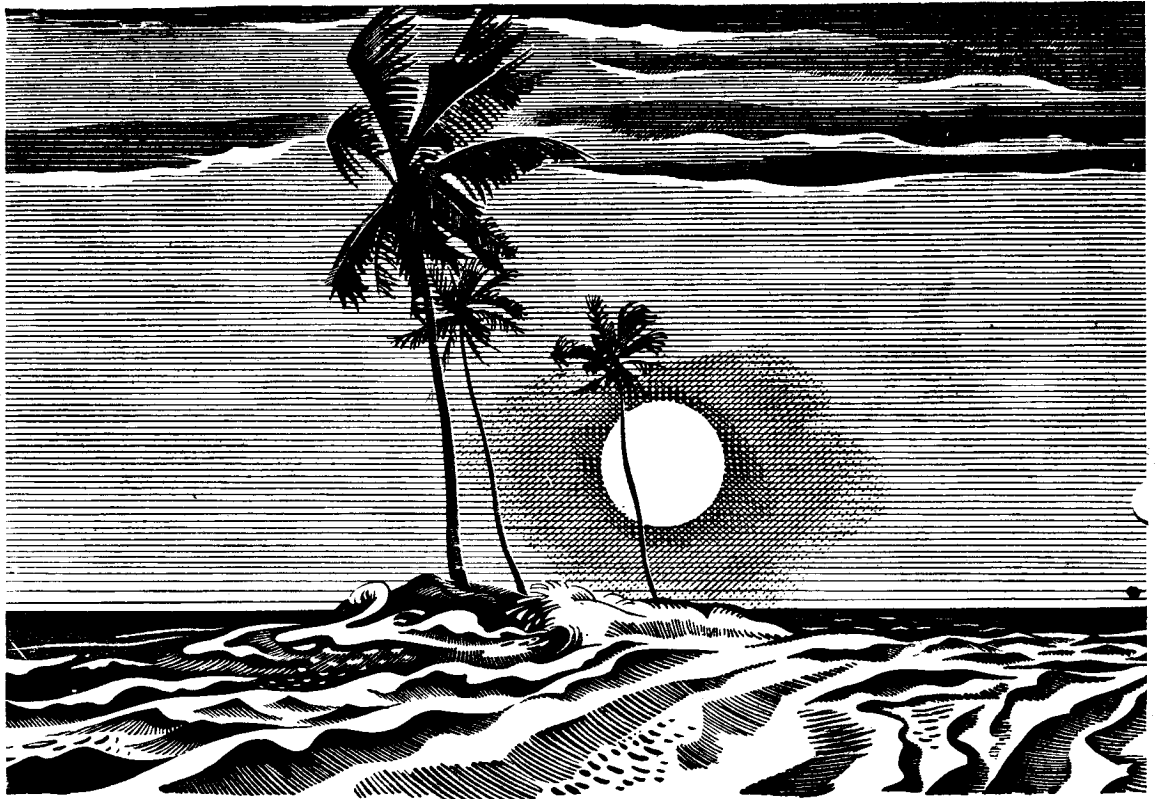

The Isle that Grew from the Sea

A little land above the surface of the sea ; white surf and leaning palms . . . but underneath, out of sight, the foundations go down deep and wide to the bed of the ocean.

So, too, with great industrial organisations like that of Philips. Their

achievements and the high reputation of Philips products are broad-based on persistent research, skilled technicians, highly-developed factories and long-accumulated knowledge and experience of the application of electricity to the needs of the modern world.

PHILIPS



LAMPS ★ RADIO ★ X-RAY

COMMUNICATIONS EQUIPMENT AND ALLIED ELECTRICAL PRODUCTS

PHILIPS LAMPS LIMITED, CENTURY HOUSE, SHAFTESBURY AVENUE, LONDON, W.C.2 (100)

Wireless World

Radio • Electronics • Electro-Acoustics

Vol. LI. No. 2

FEBRUARY 1945

Price 1s. 6d.

Monthly Commentary

Education and Training

THE average standard of living in post-war Britain will, in the long run, depend solely on the skill of our brains and hands in producing and distributing wealth. Many artificial factors that might vitiate the truth of that simple statement will have disappeared, and the fundamental issue that will confront us is probably simpler than it has been for many generations. We must find means for assuring, from our own resources, a good standard of life to a large population in a country not particularly well blessed with raw materials.

A depressing picture? On the contrary; we find it stimulating to face such a clear-cut issue. Turning to our more immediate affairs, it is not over-optimistic to hope that radio will contribute worthily to our national wealth. Let us remember that, during the Battle of Britain, when radio—in the form of radiolocation—made its greatest contribution to the national cause, we were confronted by a similarly clear-cut issue.

If radio is indeed to play a worth-while part, we must give constant thought to developing the skill of our brains and hands—in other words, to education and training. Fortunately, the matter has not been overlooked, and there has been a steady output of reports and other literature on the subject. Much of the discussion that has taken place was originally provoked by Professor Willis Jackson's paper on "The University Education and Industrial Training of Engineers, with Particular Reference to Telecommunications," read before the I.E.E. in 1943. Although nothing approaching unanimity has been reached in these discussions, several points emerge clearly. First, it is obvious that, in the view of the majority, present methods are wrong in many respects; not merely in the bare details of syllabuses or length of courses, but with regard to the fundamental principles of specialised education. Again, there is wide agreement with Prof. Willis Jackson's declared principle that study in universities should alternate with periods of work in industry. Though his paper dealt essentially with the education of the aristocracy of the profession, described as

"engineer-scientists," many of his contentions obviously apply to every grade of technician.

Many excellent points have been made in subsequent discussions; none seem more important than insistence on the fact that the present field of knowledge is so vast that the true function of real education is to produce men capable of thinking clearly and of assimilating specialised information easily and with a minimum of delay. This implies that real education must concentrate on fundamentals, and cannot be intensive. But the *educated* man can be *trained* by intensive methods. The difference in meaning between the italicised words should constantly be borne in mind.

"Sandwiching" Work and Study

Although the principle of alternating periods of instruction and work in industry is in itself admirable, we believe that the manner in which it is proposed to apply it is fundamentally wrong. The "work" periods are too short and come at the wrong time; students going into a factory for a year between school and university are likely to be a nuisance to industry, and will stand little chance of benefiting themselves. The same applies to some extent to those who spend a post-graduate year in industry before returning to their studies for a final year of specialised instruction.

A better plan would involve a more drastic "spreading" of a young man's education. We suggest that, on leaving school, he should go into industry for, say, three or four years, combining a certain amount of part-time study with his work. At the end of that time he would have come to realise the limitations of his own knowledge and the advantages of acquiring more. There would be a real incentive to learn. Further, it should at this stage be possible to make a good estimate as to the extent to which the man concerned would benefit from higher education—and in what direction. Again, industry would have benefited from his services over a reasonably long and uninterrupted period, and, in return, might be expected to give the co-operation that is so essential for any scheme of specialised education or training.

RADIOLOCATION

1. Basic Principles

By R. L. SMITH-ROSE, D.Sc., Ph.D., M.I.E.E., F.I.R.E.

(National Physical Laboratory)

For security reasons, *Wireless World* has hitherto been unable to publish more than a few lines on the essential facts of RDF, Radiolocation or Radar—the various terms applied to the location of distant objects (more particularly, enemy aircraft) by wireless methods. It is now possible to describe for the first time the fundamental principles of the apparatus which, in the competent hands of the R.A.F., provided essential tactical information that enabled our fighter aircraft so decisively to smash the mass daylight attacks of the *Luftwaffe* during the Battle of Britain.

WHEN England entered the European War in September, 1939, she was already partially equipped with a new technical weapon in the form of a novel application of radio waves to the detection of objects such as aircraft and ships. The technique of this new weapon was then known as RDF, those mysterious initials, the precise meaning of which was never quite clear even to the original band of workers in this field. At a later stage the term Radiolocation was introduced, and this certainly had the advantage of being almost self-explanatory; but it has now to be admitted with some regret that, in the technical field at any rate, this has been largely eclipsed by the arrival from America of the short word Radar, which we are told means "radio-detecting-and-ranging."

Radiolocation or Radar may be described as the art of using radio waves for the detection and location of an object, fixed or moving, by the aid of the difference of its electrical properties from those of the medium adjacent to or surrounding it. An intrinsic feature of the art is that no co-operation whatsoever is required of the object being detected, and it is in this particular sense that RDF, as it was formerly known, differs from the long-established practice of radio direction-finding. The technique of direction-finding, as known and experimented with for half a century, is really confined to the determination of the direction of a primary source of radio waves, either for intelligence purposes or for use as a navigational aid. In such cases the source of the radio waves may be on the one hand an illicit sending station, the

position of which it is required to determine; or on the other hand, the source may be a friendly radio beacon transmitter, for the use of ships or aircraft fitted with direction finders to assist the navigator in determining his own position. A third source of radio waves which are not of man-made origin, is a lightning flash; and for many years past, the positions of such lightning flashes have been determined by using two or more radio direction finders to determine the direction of arrival of the electric waves radiated from each flash. Such measurements have contributed materially to our knowledge of the nature and origin of atmospheric phenomena as they are encountered in radio communication, and they have also been applied to the location of storm centres in meteorology.

being, is merely required to reflect or scatter some of the radiation which reaches it from a radio transmitter forming part of the whole Radar installation. The detected object is thus merely a source of secondary radiation which results from its being illuminated, as it were, by the incident radiation from the primary sending station. With this definition of the subject with which we are concerned, we may now proceed to an explanation of the fundamental principles forming the basis of this new application of radio waves.

Reflection and Refraction of Electric Waves.—In his classical experiments carried out towards the end of last century, Hertz demonstrated experimentally the salient properties of the newly-

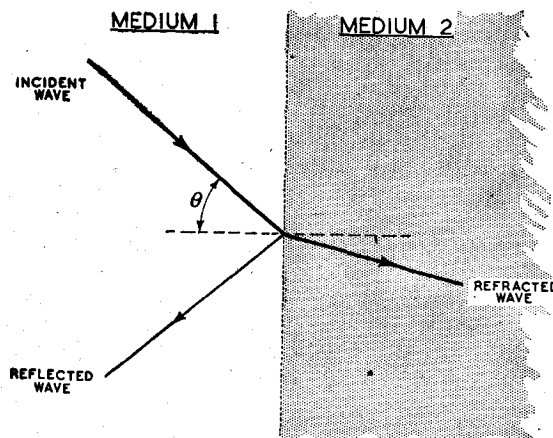

Fig. 1. Illustrating the production of reflected and refracted waves when the incident waves strike the boundary surface of two media (1 and 2) having different electrical properties.

The new art of radiolocation, however, as developed during the past two decades, requires no such co-operation, as it were, on the part of the object under examination; the latter, be it an aeroplane, ship, building or human

produced electromagnetic waves, and showed that these were similar to those of light waves when allowance is made for the difference in wavelength, the former waves being a few million times as long as those of yellow

light. Hertz showed that these long electric waves could be reflected from metallic sheets, concentrated into beams by suitably shaped reflectors, and refracted by passage through prisms of insulating material. These phenomena are due to the fact that when electric waves, of whatever

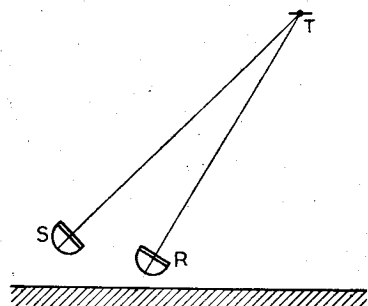

Fig. 2. The searchlight S illuminates the target T, and some of the scattered light can be detected by the observer at R. The direction, both azimuth and elevation, of the target is thus determined, but not its distance or range.

length, impinge on the boundary separating two media of different electrical properties, the path of transmission of the waves is altered; some of the wave energy passes across the boundary, but in doing so its path is bent or refracted; another portion of the wave energy is turned back from the boundary, and forms the reflected portion of the waves on the same side as the incident waves (see Fig. 1). The relative magnitudes of the reflected and refracted waves depend upon the electrical properties of the media on the two sides of the boundary, the angle of incidence (θ in Fig. 1), and the frequency or wavelength of the waves. If these quantities are known, the reflecting power of the surface of separation of the two media can be calculated; and in many practical cases, this calculation is made easier by the fact that the first medium is air under normal atmospheric conditions, when its electrical conductivity is very small and its dielectric constant is approximately unity. If the second medium is a sheet of copper, of which the conductivity is very high, nearly all the incident energy in the arriving waves will be reflected; this is the result of the re-radiation from the conduction currents set up in the copper sheet by the arriving

waves. Alternatively, the same result will be obtained with radio waves if the second medium consists of fresh water; for although in this case the conductivity is low, its permittivity is high and thus strong dielectric currents will be set up, particularly at high radio frequencies. In the case of soil or earth, which has both a moderate conductivity and an intermediate value of permittivity, a portion only of the incident wave energy will be reflected, the remaining energy passing into the medium to form the refracted waves.

From these considerations it is seen that reflection of radio waves is caused at a discontinuity or boundary between two media, and when waves in air strike a surface, which may be either a metallic conductor or an insulating medium, the waves are reflected in some degree by the surface. If this surface is smooth in the sense that it is free from irregularities of a size approaching the wavelength, then the reflection is of the specular type such as we meet with in light waves; and in such cases if the waves impinge normally on the surface, they will be reflected back along the original direction towards the source of the incident waves. If the surface is not sufficiently smooth the reflection will take place in various directions, or the incident waves

cloud—to be seen by an observer situated at R, who can then determine its bearing and angle of elevation. This is an art which is well known and has been practised for a long time; but it suffers from one serious drawback: this simple combination of a searchlight and an observer does not enable the distance of the target to be determined.

In order to make this valuable addition to the observation, it is necessary to interrupt or modulate the beam of light in such a way that the time of transit of the waves between the source and target and then back to the receiver may be determined. This important addition to the technique of visual observation was actually made as long ago as 1849 by Fizeau in his classical experiments to measure the speed with which light waves travel. Fizeau used a mechanical method of measuring the time of transit of an interrupted beam of light over a return path about three or four miles long. At that time, the distance was accurately measured and so the velocity of the waves determined; but if, as is done nowadays, a knowledge of the wave velocity as assumed, then the length of an unknown path with a reflector at the end of it can be determined.

A possible arrangement of this method of determining the dis-

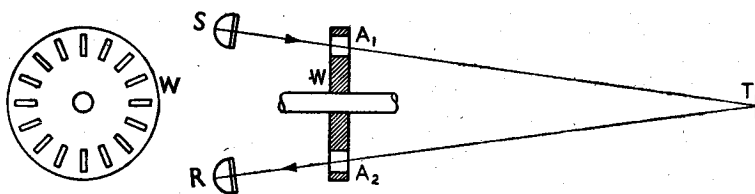

Fig. 3. Adaptation of Fizeau's classical experiment to determine the speed of light. If the speed is known, the distance A_1TA_2 can be measured by the same technique.

are scattered, as it is termed; and in this case only a portion of the reflected or scattered energy is returned along the path of the incident waves.

Measurements with Light Waves.—It is thus easy to understand how light reflected from solid or liquid media enables us to see the existence of these objects, and Fig. 2 illustrates the manner in which a searchlight enables a target—aircraft or

tance of a reflecting object by the aid of light waves is illustrated in principle in Fig. 3. As before, light from a source S is transmitted to a target at T whence some of it is reflected back to a detector or receiver at R. In front of both S and R rotates a disc or wheel W, with an even number of radial apertures in it, so that the beam of light is alternately interrupted and allowed to pass. With the disc stationary the outgoing and incoming beams

Radiolocation— pass through the corresponding slots at the end of a diameter. As the disc is rotated and its speed gradually increased, some of the light which has passed through a slot A_1 in front of S will be cut off, because by the time it has traversed A_1TA_2 the corresponding slot A_2 will have moved round through a small angle. As the rate of rotation of the disc is increased, a speed will be reached at which the returning light will be cut off by the portion of the disc between the slots. As the speed of the disc is further raised the light will again be perceived at R , since while the light is traversing the path A_1TA_2 , the disc will have rotated through an angle equal to that separating adjacent slots. Hence from an observation of the speed of the disc under these conditions, and assuming the velocity of the waves, the distance A_1T can be determined. From this type of

able to use it with light waves, but in any case, its use in this way would be severely limited to ranges normally detectable by the human eye¹ under conditions of darkness and the occurrence of clear weather. Furthermore, in typical circumstances, the time intervals to be measured are very small—about 10 microseconds per mile—and the consequent practical problems involved in the rotation of the disc at the required speed are not easily solved. The use of this technique, initiated by physicists in the latter half of the nineteenth century, thus remained limited to determinations of the velocity of light; and the resulting measurements attained a surprisingly high accuracy, notably due to the activities of Professor A. A. Michelson, who worked in this field over a period of some fifty years. In more recent times, the principle of the method was varied by modulating the beam of light at a radio frequency instead

emits radiation over a broad arc in the approximate direction it is desired to explore. When this radiation strikes an object having an appreciable conductivity or dielectric constant, some of the energy is reflected or scattered back towards the receiver which is installed moderately close to the transmitter. If the latter emits the radio waves in short trains or pulses, the time of transit of these to the reflecting target and back to the receiver can be measured, by displaying the received signals on the screen of a cathode-ray tube. The arrangement is indicated schematically in Fig. 4, where successive pulses P_1, P_2, P_3, P_4 have been emitted from the sending aerial A_1 , the first two pulses having already reached the target and been reflected back towards the receiving aerial A_2 . It is now required to determine the time of transit of any one of the pulses over the path A_1TA_2 .

The pulses of radio-frequency oscillations arriving at the receiving aerial are suitably amplified and rectified, and then applied to the vertical deflecting plates of a cathode-ray tube. If the horizontal deflecting plates are connected to a suitable time-base circuit operating in synchronism with the pulse generating circuit in the transmitter, then for a fixed distance A_1TA_2 , the received pulses will appear superimposed on one another as vertical deflections from the horizontal time-base. If, furthermore, the time-base is made to start its deflection from the left-hand side of the screen at the same instant as the pulse of radiation leaves the sending aerial, then the distance along the time-base from its origin to the position of the pulse displayed on it is a measure of the length of path A_1TA_2 . The type of picture obtained on the screen of the cathode-ray tube is illustrated in Fig. 5, in which the line OA represents the time-base which is locked to the transmitter in such a way that the length OT_1 represents the time taken by an emitted pulse to arrive back at the receiver after reflection from a target T_1 . As we know that the velocity of radio waves is substantially 186,000 miles per second, the scale of the time-base can be graduated in miles, so that the distance of the target T_1 is seen to be about 19 miles. A second received pulse is

Fig. 4. The use of pulses of radio waves P_1-P_4 , emitted at regular intervals to determine the distance of the target T from the sending and receiving aeriels, A_1, A_2 , by measuring the time of travel of the pulses along the path A_1TA_2 .

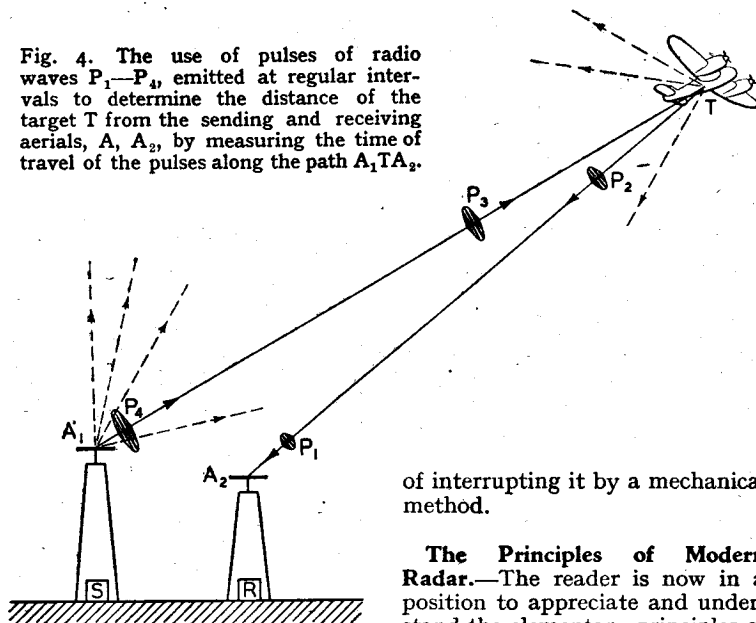

of interrupting it by a mechanical method.

The Principles of Modern Radar.—The reader is now in a position to appreciate and understand the elementary principles of radiolocation, or Radar, in so far as these are analogous to the experiments with light waves described above, but making use of the longer electric waves in the radio-frequency portion of the spectrum. A complete station consists of a combination of a transmitter and receiver. The transmitting or sending portion

measurement and the associated observations of the angular directions of the reflector T in both the horizontal and vertical planes, the position of T in three-dimensional space becomes known.

This, in essence, is the fundamental principle of radiolocation as it is practised to-day. The writer is not aware to what extent, if at all, it became practic-

¹ Modern photoelectric cell technique could be used with advantage at the present time.

seen at T_2 returned from another target at a range of about 35 miles. If one or both of these targets are moving, their changes in position are indicated by the movement of the pulses along the base-line on the screen of the

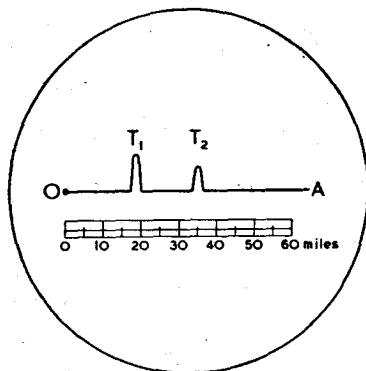

Fig. 5. Type of echo display seen on screen of cathode-ray tube. The fluorescent spot sweeps along the time base OA in synchronism with the transmitted pulses. The received echoes from two targets are seen at a distance from O corresponding to the time taken for the pulses to travel to and from the targets T_1 and T_2 . The time-base can be provided with a range scale as shown.

cathode-ray tube towards or away from the point O.

The amplitude of the pulse on the tube is proportional to the strength of the received signal, so that this naturally increases as the target from which the echo is returned approaches the receiver. When other conditions remain the same, the amplitude of the echo

also a measure to some extent of the reflecting properties of the target, for example, its size; and an experienced observer may be able to guess the nature of the target from the echo pulse seen on the tube screen.

This measurement of the distance of the reflecting body responsible for the echo signals must be supplemented by a determination of the direction of arrival of the waves in both the horizontal and vertical planes, before the actual position of the reflector in space is completely known. These measurements can be made by well-established methods for observing the bearing or azimuth (ϕ in Fig. 6) and the angle of elevation above the horizontal (θ , Fig. 6). The first observation can

be made by rotating the receiving aerial, which may at certain wavelengths be a horizontal dipole, about a vertical axis until the amplitude of the corresponding pulse decreases to zero; it is then known that the bearing is in line with the direction of the dipole. Alternatively, a pair of fixed aerials at right angles to one another can be used, connected to the field coils of a radio goniometer in the usual manner of a direction finder. Rotation of the search coil to the signal minimum position again enables the bearing to be determined.

The angle of elevation of the arriving waves can be measured by comparing the amplitudes of the voltages induced in two similar aerials mounted one above the other at a known distance apart, depending upon the wavelength in use and the range of angles of elevation it is desired to cover. This technique has been used for many years past by several investigators for measuring the angle of arrival of radio waves over long-distance communication paths, and it is directly applicable to the problem now under discussion. If the reflecting object being observed is an aircraft, then a knowledge of the range R and elevation θ (Fig. 6) enables the altitude at which the craft is flying to be determined. If the object of interest is a ship, then the angle of elevation is negligible, and the range and bearing determine its position.

The above considerations all apply to the use of wavelengths of the order of, say, 5 to 50 metres, for which the dimensions of the aerials are such as to make it impracticable to obtain very concentrated beams of radiation by the use of local reflectors. If, however, much shorter wavelengths are used, then it becomes possible to arrange what is, in effect, a radio searchlight, but with the addition of the facility for determining distance. This type of equipment was used, for example, in 1931 in the radio telephony system which was set up for operation across the Straits of Dover between England and France, using a wavelength of 18 cm. and parabolic reflectors about 10ft. in diameter. A combination of transmitter and reflector constructed on these lines, and moved together in both ver-

tical and horizontal planes, is analogous to the searchlight and observer depicted in Fig. 2. When this type of radiolocation set is trained on the target to give the maximum deflection of the received pulse, the azimuth and elevation can be read off the horizontal and vertical scales respectively, while the range of the target is observed from the position of the pulse along the time-base on the screen of the cathode-ray tube.

This is the principle of the modern radiolocation set, in the development and exploitation of which so much technical and operational effort has been devoted in the past five years or so. The story of its success, and the technical details of its develop-

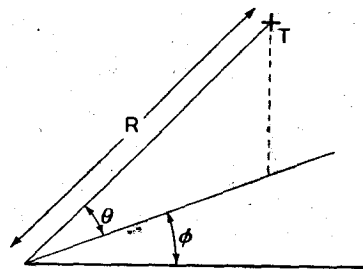

Fig. 6. The position of the target is defined by its range R, angle of elevation θ , and bearing or azimuth ϕ .

ment must await description for the time being; but there is no doubt that the early establishment and use of Radar stations has contributed very materially indeed to both our defensive and offensive operations at various stages of the present war.

COMPONENTS EXHIBITION

A PRIVATE exhibition of British radio and communications components is shortly to be held in London for the benefit of designers of equipment for the Services.

The exhibition, fixed for February 20th to 22nd inclusive, will be under the auspices of the Radio Component Manufacturers' Federation. Admission will be restricted to those with official invitation cards.

OUR PUBLICATION DATE

OWING to the rearrangement of our printing schedules it has been found necessary to alter the publishing date of *Wireless World* to the 26th of the month.

NEW DUTCH VALVES

Three Types Only for All Receiving Purposes

(From a Correspondent)

It is learned in Eindhoven that new series of indirectly heated valves have been developed by the Philips company during the occupation, and that they are to be marketed after the war. In both a 6.3V AC and in a universal series there are only three receiving types: a triode-heptode, an RF pentode, and a duo-diode-pentode. The valves are of glass-and-metal construction, are of small dimensions, and embody a keyed metal spigot for easy location in the valve-holder. In some cases the spigot is used as a contact in addition to the eight pins; top-caps are not employed; screening is provided by an internal woven-wire cylinder. It is claimed that the three valves in each series suffice for normal designs of receiver, and the use

vides 4.5 watts output at 7 per cent. total distortion for an input of 3.9V RMS. For feeding two such valves in push-pull, the triode-heptode can be used as a combined variable-gain AF amplifier and phase-inverter, as shown in the accompanying circuit recommended by the makers. Magnification varies in the ratio of 10:1 as the negative potential applied to the heptode control-grid is increased from zero to fifteen volts, and, for an output of 10V RMS, total distortion rises from 0.8 per cent. with 0.1V RMS input and maximum gain, to

The universal valves are of interest in that the heaters consume only 0.1 amp, the triode-heptode requiring 20 volts, the RF pentode 12.6, and the DD-pentode 55 volts; the half-wave rectifier in this series has a 50-volt heater. Into a load of 3,000 ohms the output valve provides, for 10 per cent. total distortion, 1.35 watts of audio power with 100 volts on anode and screen, and 4.8 watts with 180 volts. The RF pentode has a slope of 2.2 mA/V at minimum bias, falling to 0.02 mA/V when the control grid is 37 volts negative; over this range the anode AC resistance rises from 1,000,000 to over 10,000,000 ohms. The frequency-changer has a conversion-conductance of 0.75 mA/V with a grid-potential of -2V, the anode AC resistance of the heptode portion being then 1,000,000 ohms. In both the RF pentode and the triode-heptode the control-grid/anode capacity is under 0.002 μF .

Advantages claimed for the valves in these new series include the following: (a) that the inter-electrode capacities are, in the absence of a pinch and owing to widely spaced pins, lower than usual; (b) that the capacities vary less from specimen to specimen; (c) that the variation of capacities with temperature is reduced by the absence of the customary plastic base, the dielectric-constant of which commonly changes appreciably with temperature. In the case of the triode-heptode, the reduced inter-electrode couplings minimise the tendency of AVC voltage fluctuations to produce frequency-drift.

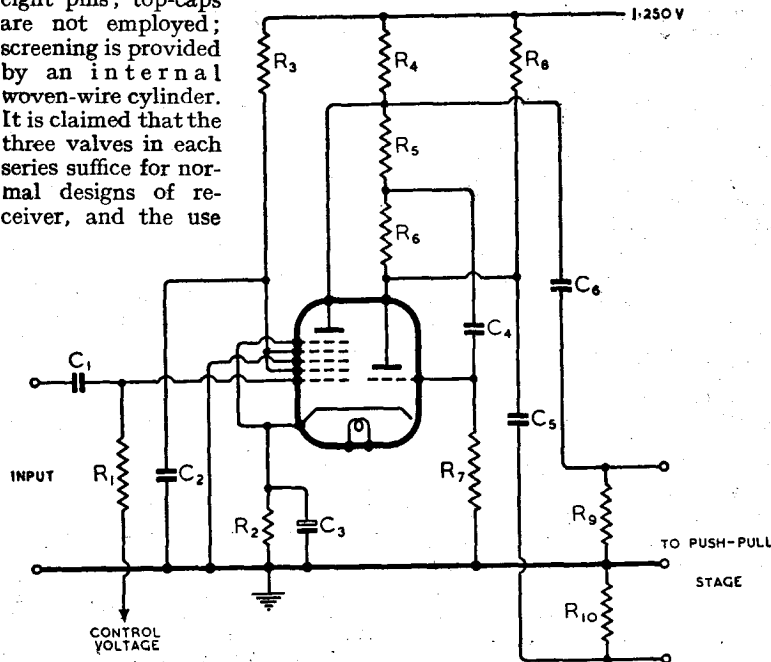

Circuit recommended by Philips, Eindhoven, for using the new ECH21 valve as a phase-splitter. Values: R_1 , 1.5 M Ω ; R_2 , 650 Ω ; R_3 , 250,000 Ω ; R_4 , 200,000 Ω ; R_5 , 1.0 M Ω ; R_6 , 1.1 M Ω ; R_7 , 1.0 M Ω ; R_8 , 100,000 Ω ; R_9 , 700,000 Ω ; R_{10} , 700,000 Ω . C_1 , 4, 5, 6, 0.01 μF ; C_2 , 0.1 μF ; C_3 , 50 μF .

of older types is deprecated. The frequency-changer, the RF pentode, and the output pentode in the AC series consume respectively 0.44, 0.2 and 0.8 amp. at 6.3V; the last-named, when working into a 5,700-ohm load, pro-

6.2 per cent. with 1.0V input and -15V bias. The triode-heptode, having no internal connection from the triode-grid to the heptode third grid, can also be used for simultaneous IF and AF amplification.

THE "PHASE-COMPRESSOR"

A Correction

In the article under the above title which appeared in our last issue the expression $(1 - R_b g_m)$ on pages 21 and 22 should read $(1 + R_b g_m)$. It is regretted that this typographical error was overlooked.

GOODS FOR EXPORT

The fact that goods made of raw materials in short supply owing to war conditions are advertised in this journal should not be taken as an indication that they are necessarily available for export.

AIRCRAFT DF EQUIPMENT

2.—The "Marconator"; a Semi-Automatic Direction Finder

THE "Marconator," a radio navigational device recently designed and developed by Marconi's Wireless Telegraph Company, embodies many new features and combines the latest techniques of air navigation and aircraft direction finding. It is described as "an adjunct to the standard Air Ministry DF equipment" and is intended for the use of the navigator or wireless operator of an aircraft.

The device enables more accurate homing to be carried out, bearings to be taken without calculation, and therefore with greater speed and accuracy than hitherto, automatic quadrantal error correction, automatic sense, back bearings to be taken and also permits of the determination of wind velocity. It would also appear to be a useful instrument with which to prepare the initial QE correction of an aircraft type.

In order to understand fully the advantages of this instrument the accompanying table should be referred to; from this it will be seen that as distinct from the manual operations involved in taking a bearing the following calculations are necessary with ordinary DF equipment:—

- (1) Add mean relative bearing (loop reading) to mean ship's bearing (compass bearing).
- (2) Add/subtract QE correction (read from calibration card).
- (3) Add/subtract magnetic variation (from chart).
- (4) Add/subtract compass deviation (from calibration card on compass).

These calculations require time even with an experienced navigator, and if a speed of 180 m.p.h. is considered it will be understood that the time spent in making the calculations leads to errors.

In the Marconator the loop scale cursor is actually linked with the master compass, a "repeated" scale of which is mounted concentrically with the normal loop scale. Thus the True bearing of a "null" (or no-signal adjustment of the loop) can be read directly and calculation No. 1 (adding loop

By CHARLES B. BOVILL,
A.M.I.E.E., A.M.Brit.I.R.E.

reading to compass bearing) is avoided. As was described in the preceding article, the master compass can be pre-adjusted for magnetic variation and deviation: thus we have also disposed of calculations 3 and 4. There remains only No. 2, the quadrantal error correction.

Once a master QE calibration has been made for a given type of aircraft mechanical devices can be included in the loop drive or on the loop pointer to crowd or spread the readings in conformity with the calibration; this is accomplished in the Marconator by a cam arrangement which retards or advances the cursor of the loop as required.

The Marconator is shown in

tion of flight are indicated at the top of the instrument at the lubber line.

The second scale, located immediately inside the compass scale, is fixed, and from it the bearings of signals received on the loop with respect to the direction of flight can be read from the loop cursor, which is mechanically fixed to the loop drive.

The loop cursor covers both the fixed loop scale and the repeated compass scale, thereby enabling both the True bearing of the signal received and also the bearing of the signal with respect to the aircraft's head to be read simultaneously.

The advantages of visual indication of loop nulls over aural nulls have already been explained; in order to provide this facility without necessity for the operator to take his eyes off the

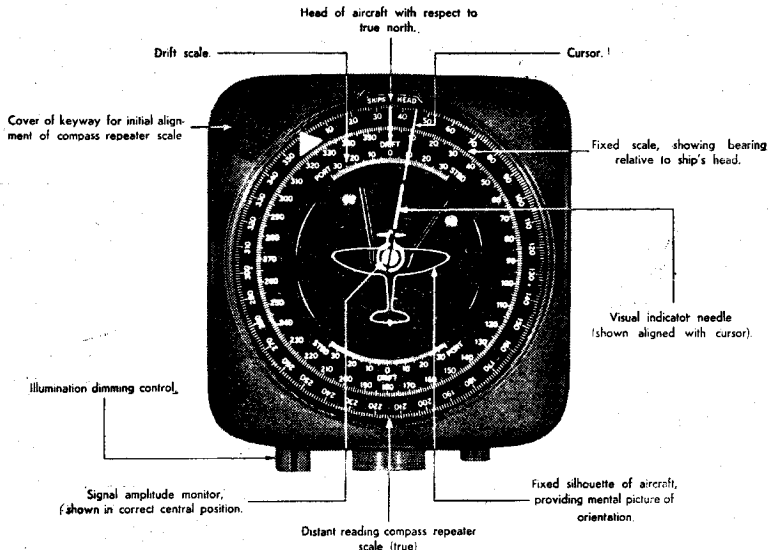

Courtesy The Marconi Review

Fig. 1. General arrangement of the Marconator indicating unit.

Fig. 1; it will be seen that two 0-360 deg. scales are mounted on the face of the instrument. The outer scale is a repeated reading of the master compass, with, of course, corrections already made. True bearing readings of the direc-

loop cursor to read the visual meter it has been incorporated in the centre of the instrument. If, however, the meter was fixed it would still entail a division of the operator's attention when taking bearings. To avoid this condition

Aircraft DF Equipment—

the designers have therefore arranged for the whole visual meter to rotate with the loop cursor and for its pointer to be in alignment with the loop cursor when in the null position of the loop. The meter used for this purpose is a centre zero type and it follows that for any loop setting other than the null point its pointer will be to the left or right of the cursor.

It will be realised that it would not be practicable to use a double-needle instrument for this purpose; the shortcomings of the single-needle instrument are, however, overcome by the inclusion of a tell-tale indicator located in the centre of the instrument, which also shows signal amplitude.

Two further scales reading 35 deg.—0 deg.—35 deg. will be seen at the top and bottom of the loop scale. These are used for drift assessment.

A small motor is built into the case which drives the outer scale, this being actuated from the master compass.

The mechanical accuracy of the Marconator is of a high order, the loop drive connection enabling an alignment accuracy of $\frac{1}{4}$ deg. to be made and backlash is reduced to $\frac{1}{2}$ deg. on a 25-foot length of drive cable. Arrangements for preset QE correction up to 15 deg. on any part of the scale are incorporated.

As magnetic deviation errors can be reduced to $\pm\frac{1}{2}$ deg. by careful adjustment of the master gyro compass, and the overall mechanical and electrical accuracy of the Marconator is claimed to be within $\frac{1}{2}$ deg, a high total

instrumental accuracy should be obtainable.

The operation of taking a bearing with this instrument is an extremely simple one, as will be seen by reference to the table below. Having tuned and adjusted the receiver it remains only to turn the loop drive in the direction which makes the cursor follow the direction in which the visual needle beneath it is pointing. When the needle and cursor are aligned the null position of the loop has been reached. The operation of following the needle in itself provides the automatic sensing. It will be appreciated that as the alignment of the cursor and visual needle is effected by rotation of the loop drive, the taking of a number of readings, such as would occur on an unstable aircraft, and establishing a mean bearing, can be carried out in a very short time.

In addition to increasing the accuracy of bearings taken on the loop the device opens up new fields of the application of radio to aerial navigation such as the hitherto almost impossible straight track homing. With the Marconator installation this would be carried out in the following manner:—

An aircraft is required to home to a beacon the W/T bearing of which is 90 deg. True. A cross wind is blowing, the speed and direction of which are not known; for the purposes of illustration it will be assumed that the wind is blowing from the south.

With normal uncorrected homing, i.e., the pilot flying on indications observed on the visual indicator only, the track flown

would not be a straight line, due to the effect of the cross wind, but would be north of the true or straight-line track, as shown in Fig. 2, although the aircraft would eventually arrive over the beacon. To fly the shortest route it is therefore necessary to head the aircraft into wind sufficiently to counteract the leeway and make a track of 90 deg. True. Using the device described the loop is set to a cursor reading of 0 deg., which places the loop at right angles to the aircraft's head. The pilot then manoeuvres the aircraft into the position which causes the visual meter on the dashboard to read with the needles crossed in the centre of the dial—the "on course" reading—and flies the aircraft to retain the visual meter in this position.

Due to the cross wind the aircraft will drift to the north side of the track and the pilot will have to alter course to maintain the "on course" reading of the visual meter.

This manoeuvre will cause the master compass scale to show a different reading—say 92 deg.—instead of the original reading of 90 deg. which will be repeated on the outer scale of the Marconator.

The operator of the instrument then off-sets the loop to make the cursor read 90 deg., which, in turn, causes the pilot's visual meter to read to the right, and he consequently alters course to make it read in the central position.

The cursor is persistently reset to 90 deg. for each variation of the master compass reading until a stable condition is reached in

COMPARATIVE TABLE OF OPERATIONS IN TAKING A BEARING

Standard DF gear with visual indicator ; remote loop scale ; magnetic compass.	Marconator.
<ol style="list-style-type: none"> (1) Select required station. (2) Check balance of visual indicator. (3) Tell pilot to "Stand-by for DF"—meaning: steer steadiest course and be ready to read "ship's head." (4) Turn loop to centre crossed needles of visual indicator. (5) Shout "Time" to pilot. (6) Note pilot's reading of "ship's head." (7) Note time of observation. (8) Note relative DF bearing. (9) Repeat (4), (5), (6), (7) and (8) two or three times and work out mean readings to minimise "yawing" error. (10) Take "sense" and, if necessary, add 180° to mean value of (8). (11) Read quadrantal correction from error curve. (12) Ask pilot for compass deviation. (13) Add: Mean "relative bearing" and mean "ship's head." <p>Add/Sub.: quadrantal correction, magnetic variation and compass deviation. Algebraic sum = True bearing.</p>	<ol style="list-style-type: none"> (1) Select required station. (2) Check balance of Marconator meter. (3) Turn loop until needle is aligned with cursor, maintaining the alignment by following up movement of the compass scale as the aircraft "yaws." The mean reading of the cursor on this scale is the True bearing.

which the cursor and visual needle beneath it are in alignment. In this condition the cursor registers the True bearing of the beacon which is being homed upon. In practice, when this condition has been reached, the needle of the visual meter and the compass

direction and can, if necessary, instruct the pilot to steer a course of 99 deg. on the compass and ignore the visual meter readings while he obtains a series of bearings from other stations from which he can plot his position and estimate the ground speed.

True from a source of signal, the aircraft would be homed to it first in the manner described above. It would then be flown on a course of 90 deg. True, the change in back bearing being observed, from which the direction of drift would be indicated.

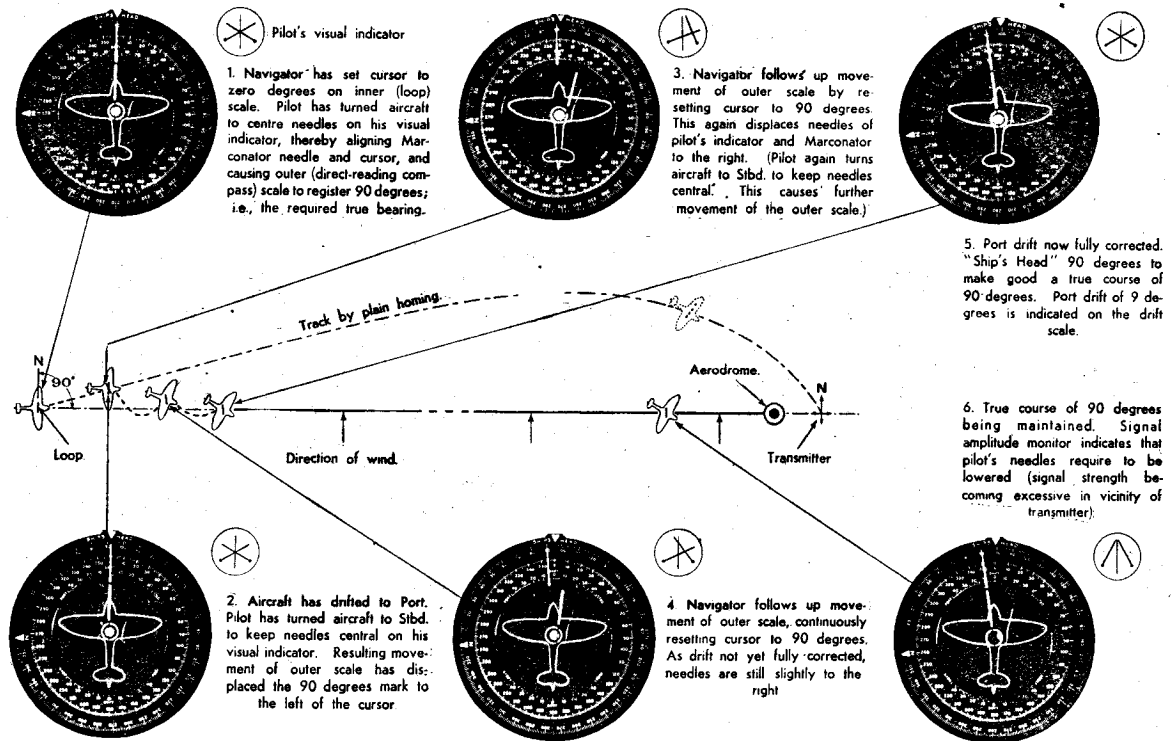

Courtesy The Marconi Review

Fig. 2. Diagrammatic representation of straight-course homing with Marconator and pilot's visual indicator. Procedure is as follows: (1) the pilot steers solely by his visual indicator, turning the aircraft as necessary to centre the crossed needles (thereby, incidentally, aligning cursor and needle of the Marconator); (2) the navigator first sets the cursor on 0° on the inner (loop) scale and awaits alignment of cursor and needle by the pilot, at which point the reading of the cursor on the outer (compass) scale will be the required true bearing; i.e., 90° in the example. During subsequent movement of the outer scale, occasioned by drift, he follows-up with the cursor the 90° mark until the resulting aircraft heading is such that, with the cursor registering 90°, cursor and needle are stably aligned, indicating that the required true course is being maintained; i.e., the drift has been corrected.

scale move gently backwards and forwards as the aircraft yaws.

In this example taken stable conditions have been reached with the aircraft heading 99 deg. True to correct the drift to the left of 9 deg., thus making good the required track of 90 deg. True.

Changes in wind direction which may occur along the route will, of course, be indicated by deviation from the required track of 90 deg., and will be shown on the master compass outer scale.

During the homing operation the operator of the device has obtained sufficient information to be able to assess the wind speed and

The stages of the homing operation are shown in Fig. 2 and will be more clearly understood if the six illustrations of the Marconator dial and the relative positions of the pilots' visual indicator are examined together.

Flying on a back bearing or attempting to fly a straight course away from a source of signal has always been regarded by air navigators as unreliable; it would seem, however, that this can be satisfactorily done by using the Marconator, and the following method suggests itself.

If the aircraft is required to be flown to a point bearing 90 deg.

The extent of the drift would soon become apparent and the new True bearing more stable, so that both the angle of drift and its direction could be read direct from the astern drift scale.

The required track could then be regained by the normal navigational method of applying to the compass course a correction of twice the measured drift angle. The calculations could then be checked by observation of the back bearing, returning to the required reading by 270 deg. True, and the compass course reset with allowance for the drift angle.

From the foregoing description

Aircraft DF Equipment—of methods and apparatus it will be understood that any transmission of which the co-ordinates are known, which lies within the waveband coverage of the receiver and which provides sufficient signal strength can now be regarded as a potential navigational aid for aircraft.

Owing to the existence of suitable transmissions in the form of broadcast, marine and commercial telegraphy stations in nearly all parts of the world, navigational pin-points thus become available

which are supplementary to the normal navigational aid services.

Under present-day conditions of flying above and through cloud, ground sights often cannot be taken for some hours at a time, and it would appear that many more radio "fixes" can be taken than ground observations made. It would therefore seem that through the ingenuity of British engineers and through the combination of their latest radio and flying instrument techniques, aircraft direction finding is destined to fill a more important rôle in

aeronautical navigation than it formerly occupied.

Literature on Aeronautical Navigation and Radio Aids.

- "Wireless Direction Finding," R. Keen (Iliffe).
- "Principles of Aeronautical Radio Engineering," P. C. Sandretto (McGraw Hill).
- "Aircraft Radio," H. K. Morgan (Pitman, N.Y.).
- "Radio Engineers' Handbook," F. E. Terman (McGraw Hill).
- "Simplified Aerial Navigation," J. A. McMullen (Griffin).
- "Through the Overcast," Assen Jordanoff (Funk and Wagnalls).

BRITISH GEAR FOR STALINGRAD

THE accompanying photograph shows electrocardiograph equipment, manufactured by A. C. Cossor, that is to be installed in the new Stalingrad hospital. A cathode-ray tube is used for observing and recording voltages developed by the heart, by the help of which its condition may be diagnosed. The schematic diagram (reproduced by courtesy of A. C. Cossor) shows the general arrangement of the apparatus and the method of photographic recording. Electrical impulses due to

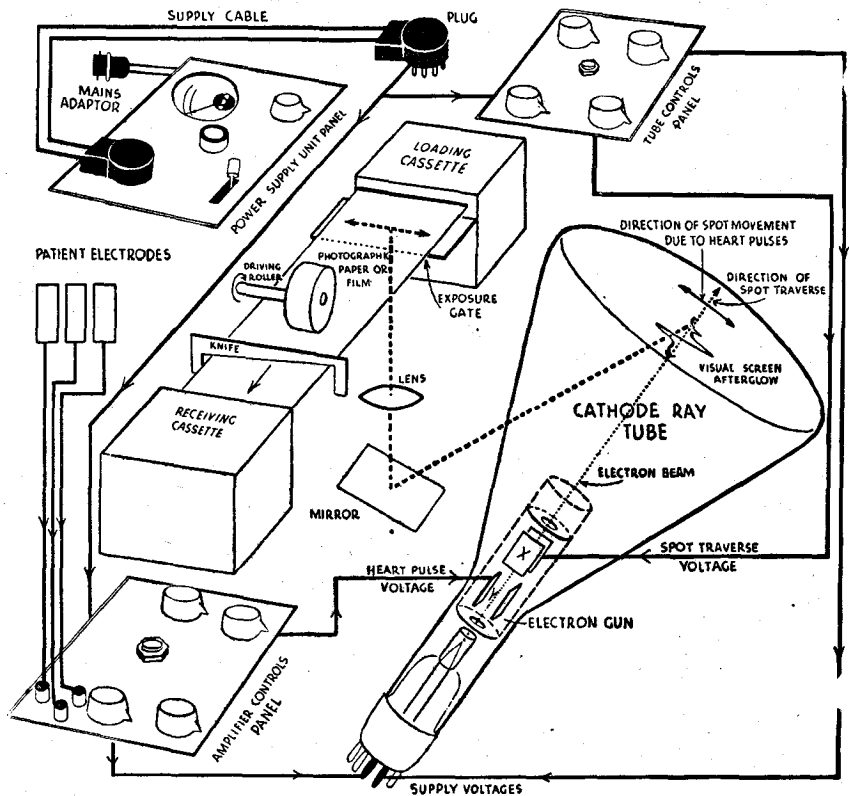

the heart are picked up through electrodes in contact with both arms and the left leg of the patient, and are then passed to a high-gain amplifier. This amplifier employs three R-C stages and a balanced input stage—five valves in all. To prevent impulses generated in other parts of the body being recorded on the cardiogram a filter eliminating frequencies above about 100 c/s is included in the amplifier. For cancelling out interfering potentials from outside sources, the amplifier is fitted with two balanced input valves, with appropriate provision for adjustment. It is stated that records can be taken under all normal conditions of interference, whether from mains or other sources. Sensitivity is normally adjusted so that one microvolt applied to the input of the amplifier gives a deflection of 2 cm. on the CR screen; simple means for re-calibrating are provided. The camera is an integral part of the equipment, and matters are so arranged that photographic records can be made at any moment desired.

WAVETRAPS

Modern Applications of a Well-tried Device

By S. W. AMOS

B.Sc. (Hons.), Grad.I.E.E.,
A.M.Brit.I.R.E.

MANY radio technicians regard the subject of wavetraps as being dead—a relic of the crystal-set or at least the pre-superhet era. They claim that the universal acceptance of the superheterodyne receiver with its great selectivity makes other aids to station selection unnecessary.

There are many flaws in this argument. Though most domestic receivers are admittedly of the superheterodyne type, there are still many TRF and crystal sets in use, and because of the increasing use of very high power in modern transmitters the need for wavetraps for use with these elementary receivers is to-day even more pressing than it was years ago. Moreover, it is customary in good superhet receivers to insert a wavetraps in the aerial coupling circuit, tuned to the intermediate frequency of the set, to avoid interference from transmitters working at or near this frequency. And there is at least one receiver manufacturer who equips his standard superhets with a means whereby a wavetraps capable of being tuned to any frequency in the medium- or long-wave bands, may be inserted in the aerial lead, should the receiver be installed very near to a powerful transmitter working at that frequency. The idea here is not so much to avoid interference by signals from the nearby transmitter with reception of transmission on neighbouring channels (though it naturally does help in this respect) but to minimise the generation of whistles.

One last up-to-date application of wavetraps may be mentioned here. It was actually the author's experience of this which prompted the present article. It is customary in the design of high-quality receivers to use a simple straight set (usually one RF amplifier followed by an infinite-impedance detector) succeeded by a quality amplifier. Such an arrangement is inherently poor in selectivity, of course, and it is indeed desirable that it should be

so, in order that a good response to all sidebands may be obtained. The selectivity is often further impaired—and the fidelity correspondingly improved—by the connection of damping resistances across the tuned circuits. In certain localities interference from strong unwanted signals is frequently troublesome with RF circuits as simple as these, and so the inclusion of wavetraps is very desirable in order to minimise such interference. Having thus justified the appearance of this article at the present time, we come to the main point of it, which is this: that a wavetraps can be designed, not only to reject a signal on an unwanted frequency, but can, at the same time, amplify signals on a certain frequency band.

and the generator V represents the EMF induced in the aerial by the passage of the electromagnetic wave over it. Suitable values of c and r for a typical outdoor aerial on the medium-wave band (and it is mainly of medium waves that we are thinking) are $200 \mu\mu\text{F}$ and 40 ohms respectively. R_2 is intended to represent the input resistance of the receiver.

At its resonant frequency, the tuned circuit L_1C_1 behaves as a pure resistance. This is indicated in Fig. 2 (b) in which this resistance has been given the value R_1

$$\text{(actually } R_1 = \frac{L_1}{C_1 R} \text{ where } R = \text{RF}$$

resistance of L_1). Again, the input resistance of the receiver is represented by a pure resistance of value R_2 . This may not be true in practice: the input resistance of a receiver may, in fact, contain a reactive component, but it is often small in value compared with the resistive component. In any case, even if the input impedance were predominantly reactive, this would not invalidate the following argument. Neglecting r and the reactance of c in Fig. 2 (b) which is justified provided R_1 is very large, the attenuation at the unwanted frequency f_U is $\frac{R_2}{R_1 + R_2}$ when the

receiver is tuned to it, or, putting this into the more convenient decibel notation, attenuation = $-20 \log_{10} (R_1 + R_2)/R_2$.

Typical practical values for R_1 and R_2 are $100,000$ ohms and $10,000$ ohms respectively. This gives the loss as $-20 \log_{10} 11 = -21$ db., a useful amount. Now when the receiver is retuned to a wanted frequency its input resistance will presumably remain at $10,000$ ohms, but it will now introduce additional attenuation at the unwanted frequency. This additional attenuation will not be very great, however, otherwise a wavetraps would not have been necessary. Let us put the attenuation introduced by the receiver at 20 db., so making the total attenuation at a frequency of f_U

Fig. 1. Fundamental circuit of series wavetraps.

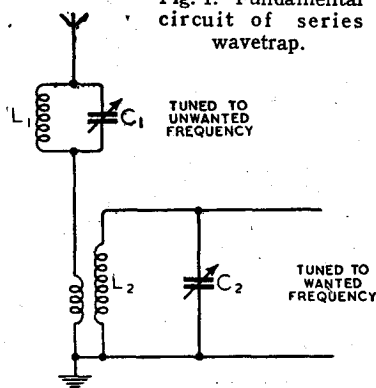

Consider Fig. 1, which shows probably the best-known of all wavetraps circuits. In this, L_1C_1 is tuned, as indicated, to the unwanted frequency f_U whilst the first tuned circuit L_2C_2 of the receiver is resonant at a wanted frequency f_w . Fig. 2 shows the equivalent electrical circuit of Fig. 1.

In Fig. 2 (a), which represents the circuit of Fig. 1 with the wavetraps omitted, r and c represent the resistance and capacitance respectively of the aerial-earth system

Wavetraps—

41 db. This may seem, on the face of it, quite a good performance, but it must be remembered that it was worked out on the assumption that the wanted and unwanted signals were of equal strength. In actual practice the unwanted station may quite easily have a signal strength 20 db. greater than that of the wanted station. In these circumstances the overall

form shown in Fig. 2 (c). Comparing this with Fig. 2 (a) which shows the equivalent circuit without a wavetrapp we can see that the condenser representing the wavetrapp is additional. This, of course, reduces the effective capacitance in the circuit and so puts up the reactance and hence the impedance, thus giving a loss, usually only a few decibels, at the wanted frequency. To be pedantic, the

Now suppose the wanted frequency is lower than the unwanted one. In these circumstances the wavetrapp will be inductive at the wanted frequency and the equivalent electrical circuit is as shown at Fig. 2 (d). We now have a series tuned circuit, formed by the inductance of the wavetrapp and the capacitance of the aerial, and at the resonant frequency of this circuit it offers minimum impedance, which will be considerably less than that of the circuit without the wavetrapp (Fig. 2 (a)). It follows that at this particular frequency the wavetrapp will enable the aerial circuit to give increased gain. If we are interested in receiving a signal on a frequency lower than the rejection frequency of the wavetrapp, then it would obviously be a good thing if we could arrange matters so that the circuit of Fig. 2 (d) resonated and so produced a boost effect at that frequency. It is a comparatively easy matter to do this. There are, of course, innumerable pairs of values of L_1 and C_1 which can be used in the wavetrapp to reject a given frequency. As shown by the formula

$$f = \frac{1}{2\pi\sqrt{L_1C_1}}$$

as long as the product of L_1 and C_1 remains the same we shall always reject the same frequency. There is, however, one pair of values of L_1 and C_1 which will enable one particular frequency which, for this particular type of wavetrapp, must be lower than the rejection frequency, to be boosted.

Actually the tuned circuit of Fig. 2 (d) is rather broadly tuned because the effective RF resistance in it is great, which means that a comparatively large frequency band (situated entirely below the rejection frequency) is boosted. Otherwise expressed this means that the values of L_1 and C_1 required to boost a particular frequency need not be very critically adhered to, provided their product is the correct value to reject the unwanted frequency. The curves of Fig. 3 are practical ones taken for three pairs of values of L_1 and C_1 , all with the same product, so that all pairs are rejecting the same frequency. These curves confirm all that has been deduced above, namely, that some loss occurs at frequencies

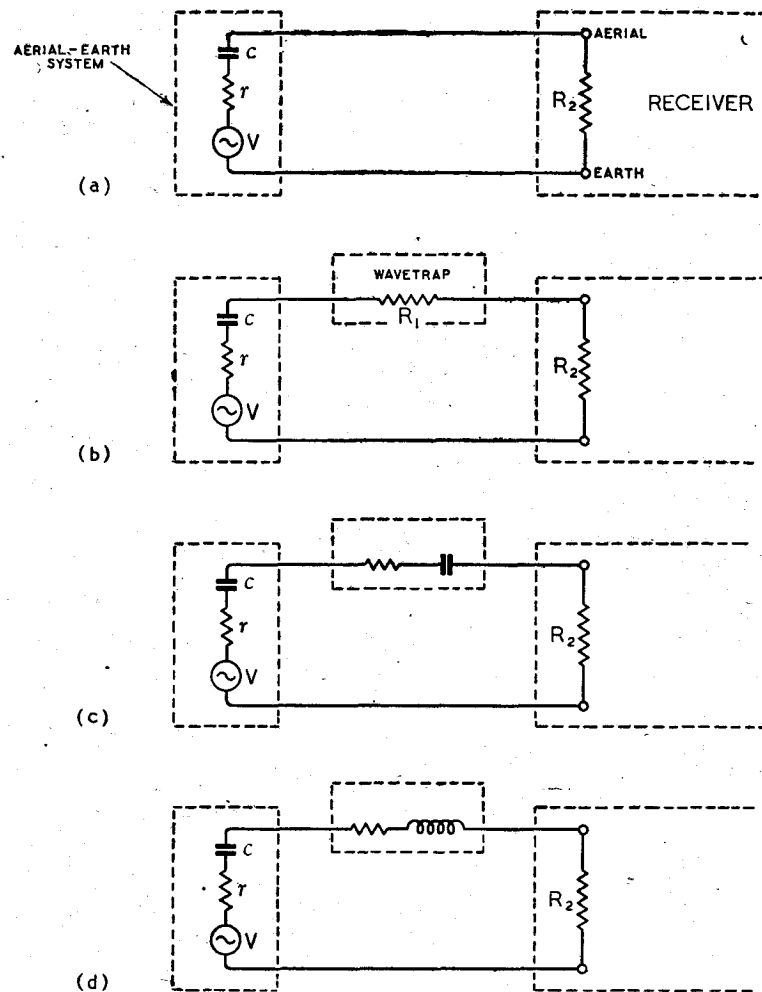

Fig. 2. Equivalent electrical circuits of a receiver and aerial-earth system (a) without a wavetrapp; (b) with a wavetrapp at its resonant frequency; (c) at frequencies higher than the rejection frequency; (d) at frequencies lower than the rejection frequency.

superiority of the wanted to unwanted signals will clearly be only 21 db.

If the wanted frequency f_w is higher than the unwanted one then the wavetrapp will be capacitive in nature at the wanted frequency and the equivalent electrical circuit of the receiver input, together with the aerial, takes the

wavetrapp also possesses some pure resistance at f_w which increases the loss even further at this frequency. The actual value of this loss will depend on how near f_u is to f_w , being greater the less the difference between them. Thus the wavetrapp causes some loss at the wanted frequency, provided this is greater than the unwanted.

above the rejection value, and that a boost occurs below it, the frequency band of the boost depending on the value of inductance used in the wavetraps.

In order to facilitate the choice

tance necessary to tune an inductance of this value to 1,200 kc/s, and in practice we shall use a larger value and adjust the condenser to give resonance at 1,200 kc/s by experiment.

the low-frequency end of the medium-wave band even without a wavetraps. It would have been better had the wavetraps done the reverse, that is, had it boosted the low-frequency end of the

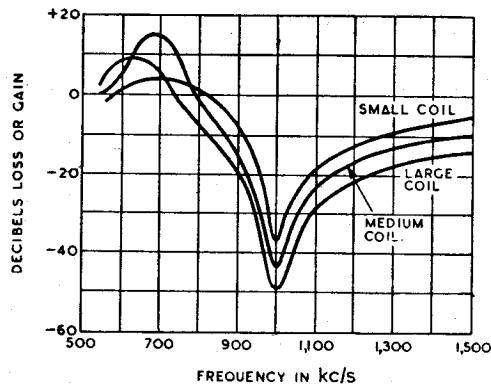

Fig. 3 (Above) Practical curves showing performance of wavetraps with various $\frac{L_1}{C_1}$ ratios. All traps were adjusted so as to reject 1,000 kc/s.

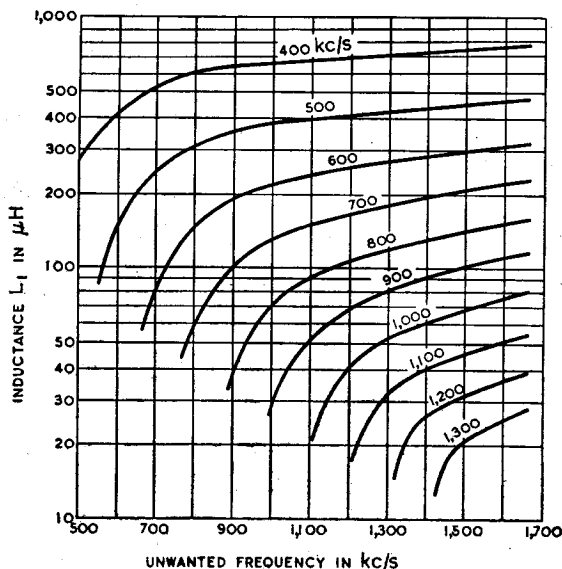

Fig. 4 (Right) Performance of series wavetraps assuming an aerial capacity of 200 $\mu\mu\text{F}$.

of a value for L_1 in practice, Fig. 4 has been prepared. From this it is possible to predict the value of L_1 to reject any particular frequency within the medium-wave band and to boost any other frequency, provided this is less than the rejection value. The curves do not depend on the value of the receiver input resistance but only on the aerial capacitance (which was assumed to equal 200 $\mu\mu\text{F}$ in the preparation of the curves). It does not matter very much, however, if the aerial used in practice has a capacitance different from 200 $\mu\mu\text{F}$ for, as pointed out earlier, the boost is very broadly tuned and the rejection frequency is, in practice, always made correct by adjustment of C_1 . For the benefit of the mathematically minded the derivation of the curves is explained in Appendix I at the end of this article.

Reference to the curves of Fig. 4, shows us that a wavetraps of 150 μH (about the inductance of a medium-wave coil) will boost 500 kc/s if tuned to 600 kc/s and will boost 700 kc/s if tuned to 1,150 kc/s, etc. Suppose we require to reject 1,200 kc/s and boost 1,000 kc/s. A coil of 38 μH will do this. We shall need, of course, to calculate the capaci-

ty necessary to consider what effect a parallel IF wavetraps (tuned to 465 kc/s) will have on the performance of a super-heterodyne receiver. Suppose an inductance of 800 μH is used (this is a value commonly used in IF transformers since it gives resonance at 465 kc/s with a conveniently small condenser). Though Fig. 4 does not quite reach these values, we can deduce from it that if $L_1 = 800 \mu\text{H}$ and if the rejection frequency is 465 kc/s, then the boost will occur at about 200 or 300 kc/s (in the long-wave band).

medium-wave band and caused a loss on the long-wave band, where it can easily be tolerated. This can be done with the aid of a shunt wavetraps, i.e., a series-tuned circuit connected in parallel with the aerial-earth terminals of the receiver as shown in Fig. 5.

The performance of this type of wavetraps is similar to that of the parallel-tuned type discussed above, in that it rejects signals on the resonant frequency of the circuit L_2, C_2 , but there is this important difference, that the circuit of Fig. 5 boosts frequencies higher than f_U and causes a slight loss at frequencies lower than f_U , in which respect it does the opposite of the circuit in Fig. 1. Again we can prepare a family of curves to illustrate the performance of Fig. 5. They are given in Fig. 6 and the derivation of them is given in Appendix II. As an example of the use of these curves we can say that an inductance of 157 μH (the usual medium wave value) will boost 1,200 kc/s if tuned by C_1 to reject 800 kc/s, and will boost 1,500 kc/s if tuned to reject 1,200 kc/s. The inductance necessary to reject 1,000 kc/s and boost 1,200 kc/s is 300 μH . The IF wavetraps, if $L_1 = 800 \mu\text{H}$ and is tuned to reject 465 kc/s, will, extending Fig. 6, boost a band of

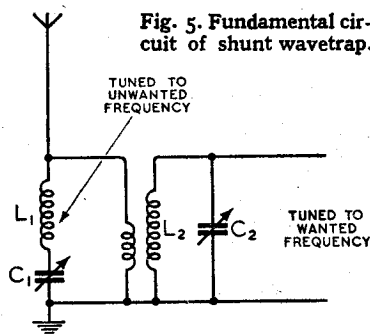

Fig. 5. Fundamental circuit of shunt wavetraps.

It will also cause a loss on medium waves. This is a pity, for receivers are usually more sensitive on long waves than on medium waves, and there is often a loss at

Wavetraps—

frequencies around 600 kc/s in value, so improving the performance of the receiver in this region where there is often a tendency to

hence comparatively ineffective, whereas a series wavetrapp will work very well, as suggested earlier in the article. On the other hand, if the input resistance is very large then the performance of a series wavetrapp will be adversely affected (since the input resistance of the receiver will for

neither low nor high, say 10,000 ohms, which is actually quite a common value. This is a fortunate thing, since we can use that type of wavetrapp which boosts the favoured part of the waveband.

This article does not by any means exhaust the subject of wavetraps. An interesting circuit is that of Fig. 8. In this, $L_1 C_1$ is arranged to resonate at a wanted frequency and L_1 and C_1 are so chosen that at an unwanted frequency $L_1 C_1$ is inductive and resonates with C_2 , so giving rejection. Doubtless one could also arrange matters so that the aerial capacitance resonates with $L_1 C_1$ and C_2 (this network being inductive at this particular frequency) in order to boost yet another wanted frequency. The mathematics would be very complicated, however. Similar principles are used in the design of "image rejector" circuits in superhet receivers.

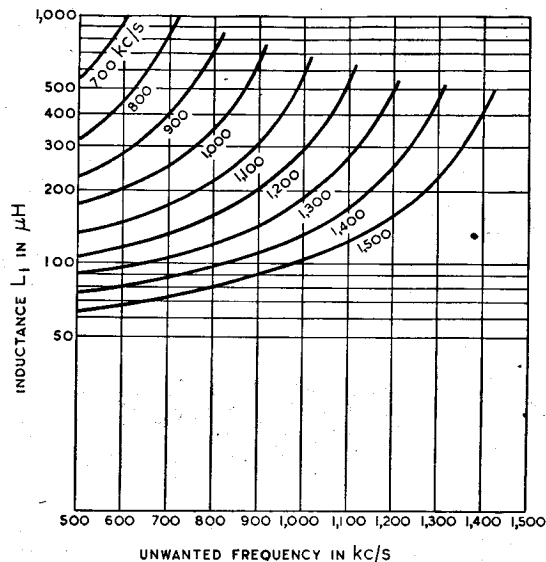

Fig. 6. Performance of shunt wavetraps. Each line indicates inductance necessary to reject frequency indicated on abscissae and boost frequency marked on curve. Aerial capacity 200 $\mu\mu F$.

a falling off in performance. Clearly, then, if no other factors influence the choice of an IF wavetrapp for a superhet receiver, the shunt wavetrapp is to be preferred to the series type. Actually, as we shall now see, the value of the input resistance of the receiver also has some bearing on this question.

We can deduce the effect of varying the input resistance of the receiver on the performance of both types of wavetrapp from first principles quite simply. If the input resistance is particularly low, then a shunt wavetrapp will be practically short-circuited, and

the most part decide the current in the circuit), but a shunt wavetrapp will work well since it will be practically undamped. The curves of Fig. 7 illustrate how the rejection and the boost vary with the value of the input resistance. These curves were not scientifically determined but are only qualitative; they do, however, illustrate that common generalisation that shunt wavetraps should only be used in conjunction with high input resistances and series wavetraps with low input resistances. Actually both types may be used with equal success if the input resistance happens to be

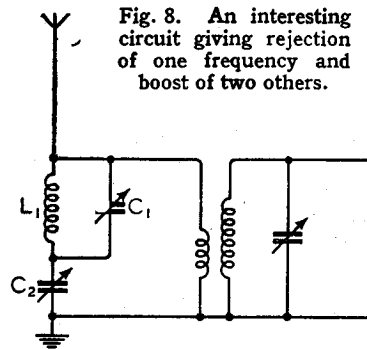

Fig. 8. An interesting circuit giving rejection of one frequency and boost of two others.

Appendix I

We must first find an expression for the apparent inductance of a parallel tuned circuit (Fig. 9) at a frequency below the resonant value. At any frequency its impedance, Z , is given by

$$Z = \frac{Z_0 Z_L}{Z_L + Z_0} = \frac{\frac{1}{j\omega C_1} (j\omega L_1 + R_1)}{j\omega L_1 + R_1 + \frac{1}{j\omega C_1}}$$

$$= \frac{\frac{1}{j\omega C_1} (j\omega L_1 + R_1)}{R_1 + j\left(\omega L_1 - \frac{1}{\omega C_1}\right)}$$

Rationalising,

$$Z = \frac{\frac{1}{j\omega C_1} (j\omega L_1 + R_1)}{R_1 + j\left(\omega L_1 - \frac{1}{\omega C_1}\right)}$$

$$\times \frac{R_1 - j\left(\omega L_1 - \frac{1}{\omega C_1}\right)}{R_1 - j\left(\omega L_1 - \frac{1}{\omega C_1}\right)}$$

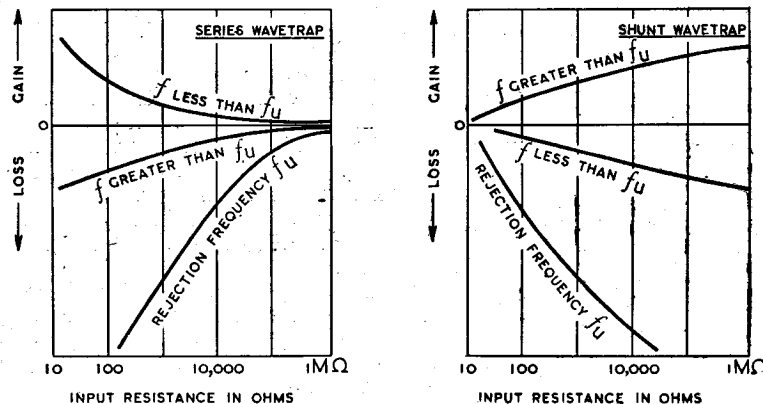

Fig. 7. Curves illustrating dependence of rejection and boost on receiver input resistance.

resistive component

$$-j \frac{I}{\omega C_1} \left(j\omega L_1 + R_1 \right) \left(\omega L_1 - \frac{I}{\omega C_1} \right)$$

$$R_1^2 + \left(\omega L_1 - \frac{I}{\omega C_1} \right)^2$$

Neglecting R_1 in comparison with

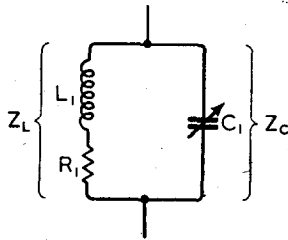

Fig. 9. Parallel-tuned circuits.

ωL_1 we have that the reactance in the circuit is given by

$$X_L = -j \frac{L_1}{C_1 \left(\omega L_1 - \frac{I}{\omega C_1} \right)}$$

Now the rejection frequency f_U is such that $\omega_U^2 = \frac{I}{L_1 C_1}$ and, using this

to substitute for C_1 , we may show

$$X_L = \frac{j\omega L_1}{1 - \left(\frac{\omega}{\omega_U} \right)^2}$$

so that the apparent inductance L in the circuit at any frequency $\frac{\omega}{2\pi}$ is given by

$$L = \frac{L_1}{1 - \left(\frac{\omega}{\omega_U} \right)^2}$$

At the wanted frequency f_W we have

$$\omega_W^2 = \frac{I}{L_1 c} \frac{1}{1 - \left(\frac{\omega_W}{\omega_U} \right)^2}$$

from which

$$L_1 = \frac{I}{c} \left(\frac{I}{\omega_W^2} - \frac{I}{\omega_U^2} \right)$$

$$= \frac{I}{4\pi^2 c} \left(\frac{I}{f_W^2} - \frac{I}{f_U^2} \right)$$

and from this expression, by giving f_W and f_U various values the curve of Fig. 4 can be determined. In this determination c was assumed to be 200 $\mu\mu F$.

Appendix II

As the wavetrap, $L_1 C_1$, is resonant at the unwanted frequency f_U we have

$$\omega_U^2 = \frac{I}{L_1 C_1}$$

from which

$$C_1 = \frac{I}{\omega_U^2 L_1} \dots (1)$$

where $\omega_U = 2\pi f_U$

At the wanted frequency L_1 resonates with the condenser formed by C_1 and c in series, and so we have

$$\omega_W^2 = \frac{I}{L_1 \frac{c C_1}{c + C_1}} = \frac{c + C_1}{c C_1 L_1}$$

from which $L_1 = \frac{c + C_1}{\omega_W^2 c C_1}$

Substituting for C_1 from (1)

$$L_1 = \frac{c + \frac{I}{\omega_U^2 L_1}}{\omega_W^2 c \frac{I}{\omega_U^2 L_1}} = \frac{\omega_U^2 L_1 c + I}{\omega_W^2 c}$$

from which

$$L_1 = \frac{I}{\omega_W^2 c - \omega_U^2 c} = \frac{I}{4\pi^2 c (f_W^2 - f_U^2)}$$

This expression is plotted in Fig. 6.

Radio Receivers and Transmitters.

By S. W. Amos, B.Sc., and F. W. Kellaway, B.Sc. Pp. 263 + xxviii; figs. 147. Chapman and Hall, 37-39, Essex Street, Strand, London, W.C.2. Price 21/-.

THIS book, state the authors, is intended to provide a bridge joining pure science and applied radio. Intended for the serious student, some knowledge of radio and physics is assumed. The result of their labours is a sound and capable textbook, which provides an excellent survey of conventional practice.

The introductory chapter deals with rather a miscellany of subjects: wireless waves, sound, modulation, transmitters, receivers, television, all receive mention. It is unfortunate that the outworn concept of an ether should be dragged in when pure science has been invoked. Succeeding chapters deal with inductance, capacitance, resonant circuits, aeriels and propagation, and valves and AF amplification; then we come to a chapter on amplifiers. Chapter VIII deals with MF and IF amplifiers and TRF receivers; Chapter IX with oscillators and super-heterodyne receivers. A useful survey of transmitters is given in Chapter X. Eight appendices deal with some differential equations, Fourier analysis, hysteresis and dimensions.

One detail which was found particularly attractive is the discussion of a commercial broadcast receiver circuit; in this the student is

BOOK REVIEW

brought into direct contact with current practice. However, certain features where this reviewer finds himself not wholly in agreement with the authors must be discussed.

In Chapter II no mention is made of Pollack's formula for inductance. This we believe to be the most useful of the lot, especially as it gives rules for the choice of wire gauge. Kelvin's expression for skin effect resistance, on the other hand, is out of place with its outlandish *ber* and *bei* functions. In the chapter on resonant circuits there is a discussion of IF transformers in which band-pass filters are mentioned; a short discussion of filter theory, so necessary both for its own sake and for video-frequency amplifier design, could find a place in this book. The chapter on propagation is, we think, unique in a book of this kind for its mention of Martyn's theorem; is it cavilling to point out that F2 is used only for the upper day-time layer? At night the only normal layer is always referred to as the F layer. A misleading statement in this chapter is that a dummy aerial is used in the setting up of the IF stages. The discussion of aeriels is, however, good, although the properties of the unterminated rhombic are not mentioned. In the chapter on valves we were not surprised to find the minus sign omitted from the $-\mu e_g$ of the equivalent generator. We have always found it difficult to keep our signs right, and we believe that

$-\mu e_g$ helps. The last term of the equation on p. 132 contains a trivial misprint. In the discussion of power amplification there is a common confusion: the load line may intersect the dissipation hyperbola, provided that the zero input point lies below the hyperbola.

The student will, no doubt, find other details with which he disagrees. Almost certainly, however, he will be attracted by the wide field adequately covered by this book. Particularly attractive is the demonstration that quite a lot of design work can be done with quite elementary mathematical knowledge. For the reader who wants a clear general picture of the "classical" radio field this book is thoroughly recommended. T. R.

AMATEUR LICENCES

ACCORDING to the annual report of the Radio Society of Great Britain, it is estimated that at least 70 per cent. of the present Home membership has never held transmitting licences. This percentage is expected to increase until licences are again re-issued.

It is anticipated by the Society that some 6,000 to 8,000 members will apply for the re-issue or issue of transmitting licences as soon as the present ban is lifted.

The report records that the membership of the Society has increased by 1,909 during the year; a record. The membership is now 7,744.

TELEVISION SOUND

Discussion on "The Television-Receiver Sound Channel" at a Meeting of the Radio Section of the Institution of Electrical Engineers held on 19th December, 1944

IN the absence of Dr. D. C. Espley, who was unfortunately indisposed, the discussion was opened by G. W. Edwards, B.Sc.

He drew attention to the interdependence of the subjective qualities of sound and vision and the danger of swamping a small picture by too high a sound level. A case could be made for the use of smaller output stages, and with the viewer seated near the axis of the loudspeaker, high-frequency response would be improved.

The choice of a suitable modulation system was a very controversial issue. Frequency modulation had been adopted in America and promised high-quality sound with substantial freedom from interference, but might present difficulties as regards cost and stability of tuning. It was possible that some wide-band amplitude-modulated systems might not be markedly inferior when all factors had been taken into account.

Carrier Frequencies

There was some justification for increasing the sound field strength by 6-10 db. relative to that of the vision signal. With regard to the relative frequencies of the carriers, the B.B.C. practice of placing the sound below the vision carrier was preferable on the score of percentage frequency-band requirements on the vision carrier, although the advantage would be insignificant at frequencies above 50 Mc/s and for a 405-line standard. The American practice of using a higher frequency sound carrier was preferable in a receiver designed to take advantage of constancy of sound-carrier/vision-carrier frequency spacing, and in which, as is usual, the sound intermediate frequency is smaller than the vision intermediate frequency, owing to the smaller percentage tuning range in the local oscillator to cover a number of stations.

In the discussion which followed there was general agreement that a sound carrier of the same order of frequency as the vision carrier

was desirable. But under the conditions likely to apply in this country there was no necessity to fix any rigid frequency relationship between the carriers, though considerations of filter design gave a bias in favour of placing the frequency of the sound carrier below that of the vision channel.

The American decision to adopt frequency modulation for the sound channel and the possibility of realising in this country the advantages claimed for this system from the point of view of interference suppression were freely discussed. The greater cost and complication of a frequency modulation receiver and the need for exact tuning, possibly by means of automatic frequency control, were stressed. It was agreed that complementary pre-emphasis and de-emphasis were needed to control the virulence of the high-frequency energy in the residual noise, but if the degree of pre-emphasis was based on the average distribution of energy in the audio spectrum there was a danger of overmodulation in the high audio-frequency region from peaks associated with transients.

Some of the improvements in quality attributed to frequency modulation were in fact due to the wider frequency band available on a UHF channel, and, it was thought, could be realised with equal facility in an amplitude-modulated system. So far as susceptibility to interference from motor car ignition systems was concerned, the shortcomings of amplitude modulation could be considerably reduced by the inclusion of a limiter designed to follow the fringe of the modulation envelope in the receiver. The simultaneous transmission of separate amplitude modulation and frequency modulation sound channels, situated on either side of the vision channel, would enable manufacturers to satisfy the demand for inexpensive receivers while the rival claims of the two systems were being resolved.

There was some division of opinion on the need for excep-

tionally high quality in the sound channel. It was pointed out that in some pre-war television receivers the degradation in quality relative to broadcast receiver standards resulting from the use of a smaller loudspeaker unit in a cabinet designed primarily to accommodate the cathode-ray tube was accepted by the viewer without comment, probably because his attention was concentrated on the picture. Other speakers held the view that, since the origins of the sounds could be seen, the challenge to comparison with reality was greater and that the reproduction, particularly of small incidental noises, should be of the highest possible standard. It was agreed that there should be closer association in the receiver of picture and sound sources; this might be achieved by mounting the CR tube inside the loudspeaker aperture. Discontinuities in tonal balance should be avoided, or dealt with at the transmitter. The necessity for manipulation of controls at the receiver, once the programme had started, would be less tolerable with television than with normal sound broadcasting.

Practical Tests

In the course of summing up the discussion, the Chairman said that the rival claims of frequency modulation and amplitude modulation systems could not be settled by theoretical considerations alone, and that a big improvement in signal-to-noise ratio would have to be proved before those responsible for the service would be justified in asking the public to pay for the higher cost of a frequency modulation system. The high standard of the pre-war television sound channel had been widely acknowledged. That standard would be maintained and, if possible, improved, but thorough tests would be necessary before finally deciding the modulation system to be used.

Fifteen speakers took part in the discussion.

Angles on BRIMAR PRESTIGE

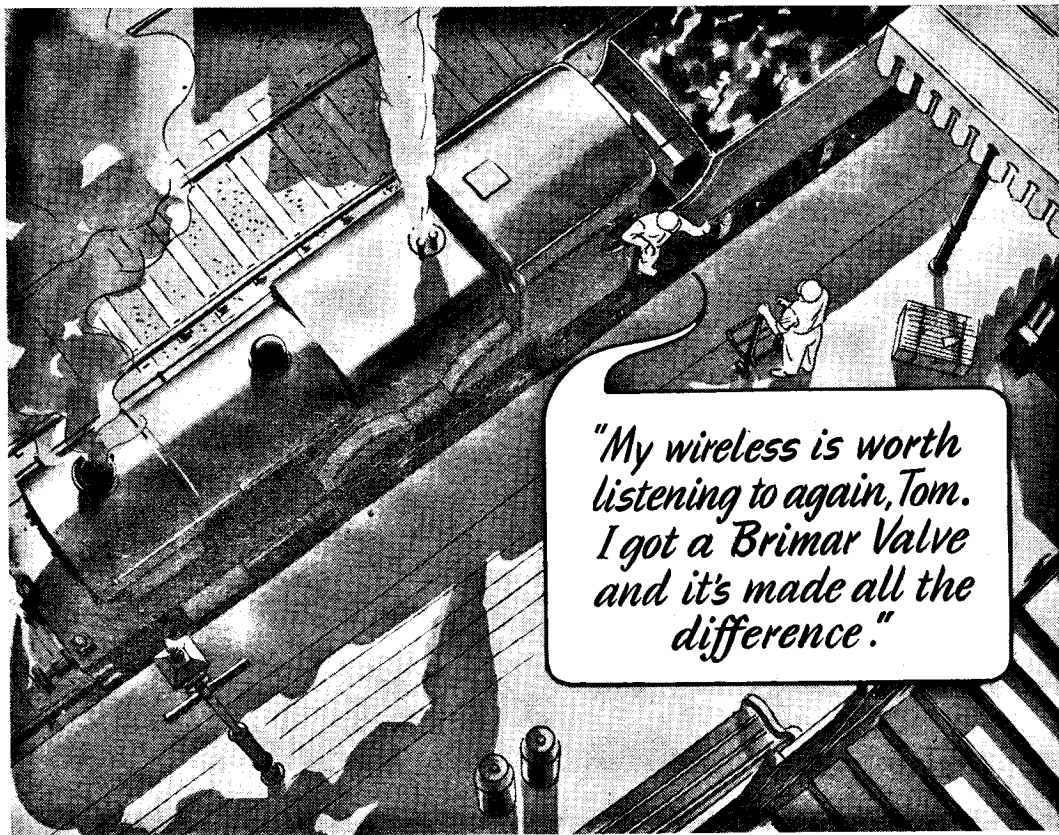

"My wireless is worth listening to again, Tom. I got a Brimar Valve and it's made all the difference."



Brimar Valves operate to very close limits with complete reliability. "Peak performance" is an automatic result of their use. Although valves are still in short supply, you may be able to get the Brimar Valve you require.

BRIMAR

BVA

VALVES

STANDARD TELEPHONES AND CABLES LIMITED, FOOTSCRAY, SIDCUP, KENT.



ADVERTISEMENT OF THE TELEGRAPH CONDENSER CO., LTD

MECHANISM OF RADIO FADE-OUTS

A New Theory

AMONG the Abstracts appearing in the December issue of *Wireless Engineer* is one which gives some new information to those who are interested in short-wave propagation. It deals with a Paper* by Professor R. Jouaust on the causation of radio fade-outs—sometimes called "sudden ionosphere disturbances" or "Dellinger fade-outs."

It has some time been known that fade-outs of this kind are due to sudden increases in the ionisation of region D of the ionosphere, resulting in complete absorption of the radio "sky" waves in that region. Also that these sudden rises in the ionisation are brought about by "chromospheric eruptions"—or "solar flares"—on the sun. In a number of cases the time of observation of such a solar flare has been found to coincide with the time of the beginning of a radio fade-out. It remained to be explained, however, how such a considerable increase in the ionisation could occur so deep down in the atmosphere—80 km. above the ground—from a solar disturbance whose brilliance (so far as its visible radiations are concerned) is only slightly above that of the sun's surface, and, furthermore, which only affects a very small portion of the visible surface of the sun. It would not appear that the higher ionospheric layers (E and F) are at all affected by the ionising radiation passing through them from the solar disturbance, for short-wave signals which are of high enough frequency to escape complete attenuation in region D (this frequency varies with the intensity of the disturbance) are returned from region E or F in the normal way. Again, as the absorbing layer begins to lose its ionisation, signals on frequencies which have hitherto been completely absorbed within it are returned to earth by the upper layers, indicating that they have existed in a normal state throughout the disturbance.

Prof. Jouaust explains the mechanism of the sudden ionisa-

tion increase in this way: To reach to the level of region D the solar radiations must be of longer wavelength than 1,750 Angstrom Units. Otherwise they would be absorbed by the gases which exist higher in the atmosphere, and, as we have seen, they are not so absorbed, but pass through the higher atmosphere without appreciable effect. Normally, radiations of this wavelength can only come from the photosphere (the visible portion of the sun) or from the lower layers of the chromosphere (the region surrounding it). The upper layers of the chromosphere emit only rays of shorter wavelength than 1,750 Angstrom Units, such as would be absorbed by gases in the upper regions of our atmosphere. Also, in the upper layers of the chromosphere

much of the longer wavelength radiation coming from the photosphere is absorbed, and consequently the amount of such energy which escapes from the sun is *relatively* small, and the ionisation which it produces in region D is thus *relatively* weak. During the eruptions, however, quantities of matter from the photosphere are thrown up into the surface of the chromosphere, and the longer wavelength radiations emitted from it escape from the sun without suffering any absorption in the chromosphere. On reaching our atmosphere they are thus of relatively great intensity compared to those of the same wavelength *normally* reaching it and so are capable of producing a great increase in the ionisation of region D. T. W. B.

ELECTRIC LAMP FAILURES

A "Thermionic" Fault

THE lamp upon which these chance observations were made was a 100W lamp of cheap type which had already seen many hours' service. It was in use in the proper position, i.e., vertical, cap upwards.

After the light had been on for some time it was noticed that it appeared to be varying in a curious manner, so the shade of the lamp was removed and a close inspection of the bulb was made. It was found that at the second "spoke" from one end the filament was completely severed and the section of filament which should have been strung between spoke 2 and spoke 3 was hanging freely but was not making contact in any way. *Both sections of the filament were still glowing, even the loose hanging portion right down to its fused end.* This at first sight seemed so remarkable that the greatest care was taken to see that there was no physical circuit across the gap. The distribution of light from the lamp as a whole varied as the loose bit of filament was made to hang in various positions. (This, in fact, is what had called attention to the lamp), but the filament brightness itself did not appear to change. After this inspection temptation became too great and the lamp was switched off and, of course, it failed to relight when switched on again.

The only explanation I can offer is that this "two plate diode," once having been raised to the required temperature, is capable of maintaining itself. A considerable emission current can be given out in each half-cycle by one or other of the filament portions and this can maintain the necessary heating in two ways: (a) by the consequent flow of current in the filament portions, and (b) by bombardment.

A second effect noticed with this lamp was that it emitted a slight noise of mechanical vibration of high and somewhat indeterminate frequency—the kind of noise I should associate with the natural vibration of the metal part of the internal structure.

Whatever the explanation may be I am confident, now that I have "caught a lamp in the act," that this is the secret of the lamp which appears to be quite all right when it is switched off and appears to die cold. K. G. B.

[The lamp, with its open-circuited filament, would appear to have functioned on the principle of the "Point-o-lite." Though it is generally believed that moribund electric lamps are fruitful sources of interference with radio reception, it is not clear whether lamps with the particular defect described are likely to be serious offenders.—Ed.]

* 3788 "The Mechanism of Fade-outs of Radioelectric Waves," R. Jouaust. (*Comptes Rendus* [Paris] 1st/29th March 1943.)

WORLD OF WIRELESS

CANADA CALLING

TEST transmissions from Canada's new short-wave broadcasting station at Sackville, New Brunswick, were begun on December 21st on frequencies of 15.22 and 17.82 Mc/s. Transmission times are from 1045 to 1315 GMT.

It is understood the station will be brought into regular service on February 11th.

The two American-built 50-kW transmitters are at present equipped with an aerial array directed towards Europe. By reversing this array the station will be able to serve the West Indies, Mexico and New Zealand. Other arrays will, in due course, be added to the station's aerial system, which it is understood is an adaptation of that used by the B.B.C.

Peter Aylen, who has been with the Canadian Broadcasting Corporation for twelve years, has been appointed supervisor of the C.B.C. international short-wave service.

The Sackville station is being financed by the Canadian Government and operated by the C.B.C.

Reception reports are welcomed and should be sent to A. E. Porter, Canadian Broadcasting Corporation, 32, Great Castle Street, London, W.1.

WIRELESS HONOURS

FOR services to education Dr. A. P. M. Fleming, C.B.E., director of Metropolitan Vickers Electrical Co., is created a Knight Bachelor in the New Year Honours List. He is chairman of the Education and Training and Personnel Sub-Committee of the I.E.E. The Committee's report on part-time education and training for engineers is summarised in this issue.

B. E. Nicolls, senior controller, B.B.C., is created a C.B.E.

Dr. F. C. Williams, principal scientific officer, Telecommunications Research Establishment of the Ministry of Aircraft Production, is appointed an O.B.E.

H. H. B. Dyer, radio officer on the Great Western Railway vessel *s.s. St. Andrew*; Albert G. Newman, assistant inspector of the G.P.O., Wireless Telegraph Section; and Harold S. Walker, head of the B.B.C. valve department, have been appointed Members of the Order of the British Empire.

H. J. Mortlock, chargehand in the Admiralty Civilian Shore Wireless Service, receives the British Empire Medal.

In addition to the above there were a number of awards to members of the wireless industry.



Col. Sir A. Stanley Angwin, D.S.O., Engineer-in-Chief, G.P.O., since 1939, was created a Knight of the Order of the British Empire in the New Year Honours. Sir Stanley has been a member of many international radio committees and has served on the Government Television Committee since its formation.

HONOURS FOR THE INDUSTRY

THE names of a number of manufacturers in the industry appear in the New Year Honours List in which executives and employees have received decorations for their part in the industry's great production drive.

Frederick Smith, general manager of the M.O. Valve Company, becomes an O.B.E.

The following are among those who become Members of the Order of the British Empire:—

H. R. Angell, superintendent, rectifier department, Westinghouse Brake and Signal Co.; S. H. Brewell, works director, A. H. Hunt; H. F. Buckmaster, technical director and works manager, McMichael Radio; J. N. Lawrence, production manager of one of Philips' factories; R. G. Powell, development engineer, Decca Radio and Television; and K. McI. Whyte, production manager (Bradford Factories), G.E.C.

Among the recipients of the British Empire Medal were Miss S. Alston, senior operator, M.O. Valve Co.; W. A. Dawson, tool room foreman, Whiteley Electrical Radio Co.; G. T. Egan, tool room superintendent of one of Philips' factories; Miss A. S. Forster, forewoman, Standard Telephones and

Cables; Miss M. King, senior chargehand, Telegraph Condenser Co.; Mrs. D. E. Sincock, welfare supervisor, Marconi's Wireless Telegraph Co.; H. E. Smith, foreman, Bush Radio; and K. Warwick, assistant chief inspector, Philco Radio and Television Corporation.

RADIO OFFICERS' DISCHARGE

ALARGE increase in the number of applications from Radio Officers for discharge from the Merchant Navy is recorded by the Radio Officers' Union, which states that any officer is entitled to apply for his discharge but that releases will depend primarily on the requirements of the Service.

It is pointed out that when a man is discharged from the Merchant Service he becomes liable for call-up for further service with the Armed Forces, in accordance with his registration age group.

TECHNICAL APPOINTMENTS

IN an endeavour to meet the needs of the aspirants to "higher appointments," who will be coming out of the Services at the end of the war with Germany, plans have been made for the reorganisation of the existing Appointments Department of the Ministry of Labour.

These plans for assisting the resettlement of men and women in posts which call for administrative, supervisory, managerial, professional or technical qualifications, are being made as a result of the recommendations of the Hankey Committee appointed last year.

Sir Frank Lindley, C.B., lately Comptroller-General of the Patent Office, and Dr. W. Wardlaw, Professor of Physical Chemistry, University of London, have been appointed scientific advisers to the Appointments Department.

RECONVERTING INDUSTRY

THE Board of Trade is establishing a regional organisation to assist firms in their change-over from war to peacetime production. The President of the Board of Trade, explaining the objects of the new organisation, said that it aimed at avoiding the "Whitehall bottleneck" as far as possible, and that it was an important piece of preparatory planning work ready for the cessation of the war against Germany. Its four main functions are: The reconversion of industry, particularly engineering; the derequipping of factories, etc., and the allocation of surplus Government factories; the distribution of indus-

try, with special regard to the new development areas; and the deconcentration of industry and the release of labour and materials.

WHAT THEY SAY

A CONDITION OF PEACE?—The disarmament of Germany will have to include radio disarmament.—*M. Jean Guignebert, director-general of the French Broadcasting System.*

TELEVISION IS READY, NOW!—But there are those who would now hold television back, by relegating it to the Siberia of new ultra-high frequency channels—there to start all over again, working out a new and questionable existence!—"Electronic Industries," *New York.*

AMERICAN OPINION.—The European [broadcasting] system (which appears on its way out) involves payment of receiving set licence fees. . . . "Broadcasting," *Washington.*

ALTRUISTIC.—Radio is not, never has been, and I hope never will be a purely profit-making business.—*Lord Halifax, addressing the Radio Executives' Club in New York.*

TELEVISION PROGRESS

THE first conference of the American Television Broadcasters' Association has been held in New York. Details, however, of the plans for the "far reaching industrial, commercial and educational uses" of television after the war have not yet been received.

According to the French journal, *Radio 44*, regular television transmissions for three hours a day on three days a week from the Paris station are to begin this month.

As to our own service, it is probable that the eagerly awaited report of the Government Television Committee appointed just over a year ago under the chairmanship of Lord Hankey, may be published even before this note appears in print.

CIVIL AVIATION RADIO

IN a statement at the conclusion of the second Commonwealth and Empire conference on the use of radio in post-war civil aviation recently held in Ottawa it was announced that the third conference would probably be held in Australia next summer.

Sir Robert Watson-Watt, head of the United Kingdom delegation, said he believed "the conference has shown more clearly than ever before that the transfer of modern radio technique, and in particular Radar techniques, from military to civil applications will make a noteworthy contribution to the regularity, punctuality and safety of civil air transport services."

Wireless World

"SCIENCE IN PEACE"

IN order to draw attention to the need for science to be used as fully in peacetime as it has been during the war, a conference to discuss the use of science in the post-war world has been organised by the Association of Scientific Workers.

The first session on "Science and Production" will begin at 2.15 on Saturday, February 17th.

Sir Robert Watson-Watt, F.R.S., will be in the chair at the second session at 10.0 on Sunday, February 18th, when the theme will be "The Future Development of Science."

"Science in Everyday Life" is the theme of the third session at 2.30 on Sunday.

The conference on "Science in Peace" will be held at the Caxton Hall, Victoria St., London, S.W.1.

OUR COVER

THIS month's illustration shows a group of Erie wire-wound resistors, with vitreous enamel protective coatings. This type of relatively high-wattage resistor is largely used in present-day radio and electronic equipment where high stability is needed.

OBITUARY

P. K. O'Brien.—It is with regret we record the sudden death of P. K. O'Brien, assistant managing director of Murphy Radio, at the early age of 33, following a brief illness. He joined the company in 1934 as a professional economist to undertake "consumer research" and was appointed to the Board as assistant managing director in 1942, in which capacity he was largely responsible for Murphy's expansion to meet the demands of the Services. He served on some of the most important of the R.M.A. committees.

PERSONALITIES

Lord Reith is to visit the Dominions and India to discuss with the Governments the reorganisation of the Commonwealth telecommunications services. Among those accompanying him will be Sir Stanley Angwin, G.P.O. Engineer-in-chief. In view of this Government mission Lord Reith has resigned from the Board of Cable and Wireless.

Sir Robert Watson-Watt, pioneer of radiolocation, has received the honorary degree of Doctor of Science from the University of Toronto. It is 96 years since the award of such a degree was made.

A. W. Ladner has retired from his position as Principal of Marconi's School of Wireless Communication after 32 years' service with the company, but will continue to act in an advisory capacity.

N. C. Stamford, who was previously with Marconi's Wireless Telegraph Co., is taking A. W. Ladner's place as Principal of the Marconi Wireless School. He has just left the teaching staff of Manchester University.

Trefor Williams, late of the B.B.C., has joined the staff of Partridge Transformers as chief designer in charge of the Technical Department.

H. S. Bennett is now telecommunications manager and technical adviser to the chairman and managing director of the Philco group of companies. He has been released from the Ministry of Supply to take up this appointment.

IN BRIEF

E. K. Cole appears to be the first company to include Radar in its officially stated scope of activities. In the revised memorandum of association recently issued by the company, provision is made for the manufacture of "radio, Radar, television, telecommunication and electronic apparatus, articles, appliances, products and things required for or capable of being used in connection with the transmission, reception, recording and reproduction of signals, pulses, sound, pictures, television images, films, facsimile and other matter actuated or created by magnetic, electro-magnetic or electro-static energy or radio activity."

Welsh R.I. Club.—Following an inaugural meeting in December, the Radio Industries Club of Wales and Monmouthshire has been formed and is affiliated to the original R.I. Club in London. H. B. Ducé has been elected the first president; J. F. Paull, chairman; W. Summerville Vernon, vice-chairman; A. G. W. Saunders, hon. secretary; and F. C. King, hon. treasurer. Details of membership are obtainable from the honorary secretary at Magnet House, Kingsway, Cardiff.

Wireless for the Blind.—The supply of sets urgently needed for sightless listeners has been temporarily stopped as the result of a flying bomb which wrecked the factory where they were being manufactured. The secretary of the British Wireless for the Blind Fund, W. McG. Eagar, was appointed a C.B.E. in the New Year Honours.

Radio Society of Great Britain.—The following members have been re-elected to the R.S.G.B. Council for 1945: E. L. Gardiner (G6GR), president; S. K. Lewer (G6LJ), vice-president; A. J. H. Watson (G2YD), hon. treasurer; H. A. M. Clark (G6OT), hon. secretary; A. O. Milne (G2MI), hon. editor; F. Charman (G6CJ), D. N. Corfield (G5CD), F. G. Hoare (G2DP), and W. E. Russell (G5WP) as ordinary members of the Council. In addition, the following three new members were elected to the Council: E. H. Laister, S. E. Langley (G3ST), and Lt. Col. K. Morton Evans (GW5KJ).

St. Pancras Radio Society.—Classes conducted by this Society have now restarted, and new members are welcomed. All enquiries should be addressed to the Honorary Secretary, S. Barnett, 6, Anson Road, London, N.W.2.

MEETINGS

Installation of Electrical Engineers

Radio Section.—Flt. Lt. C. B. Bovill will give a paper on the comparison between fixed and trailing types of aircraft aerials on the 900-metre waveband at a meeting to be held on February 7th.

On February 20th a discussion on "Aspects of Post-war Valve Standardisation" will be opened by A. H. Cooper.

"Multipath Interference in Television

World of Wireless—

Transmission" is the subject of a paper to be given by D. I. Lawson, M.Sc., on February 28th.

These meetings commence at 5.30 at the I.E.E., Savoy Place, Victoria Embankment, London, W.C.2.

Students' Section.—Dr. W. Wilson will lecture on "The Cathode Ray Tube and its Applications" at a meeting at the I.E.E., London, at 7 o'clock on February 13th.

South Midland Centre.—A discussion on television will be opened by Dr. D. C. Espley at a meeting of the Radio

Group to be held at the James Watt Institute, Gt. Charles Street, Birmingham, at 6 o'clock on January 29th.

Television Society

At a meeting of the Society to be held at the I.E.E., Savoy Place, London, W.C.2, at 6 o'clock on February 27th, Dr. H. P. Williams will speak on "Vertical v. Horizontal Polarisation."

Institution of Electronics

North-West Branch.—A lecture on "Neon Stroboscopic Lamps," with special reference to lamps of the cold

cathode type, will be given by D. Besso and H. Brown at a meeting to be held at 7.30 on February 2nd at the Reynolds Hall, College of Technology, Manchester. The lecture will be followed by a demonstration. Non-members may obtain tickets on application to L. F. Berry, 14, Heywood Avenue, Austerlands, Oldham, Lancs.

Institution of Factory Managers

South-East (London) Branch.—A meeting of this branch will be held at Kingsway Hall, Kingsway, W.C.2, at 2.30 on February 17th.

NEWS IN ENGLISH FROM ABROAD

Country : Station	Mc/s	Metres	Daily Bulletins (BST)	Country : Station	Mc/s	Metres	Daily Bulletins (BST)
America				India (contd.)			
WRUA (Boston) ..	6.040	49.67	0000	..	9.630	31.15	1550
WNRX (New York) ..	6.100	49.18	0000	..	11.760	25.51	0800, 1300
WOOC (Wayne) ..	6.120	49.03	0000	..	11.830	25.36	0800
WNRI (New York) ..	7.565	39.65	0000	Iran			
WOOW (Wayne) ..	7.820	38.36	0000	EQB (Teheran) ..	6.155	48.74	2225
WRUS (Boston) ..	9.700	30.93	0000, 1200	Mozambique			
WLWRI (Cincinnati) ..	9.750	30.77	0000, 1200, 1500, 1730, 2000	CR7BE (Lourenco Marques) ..	9.830	30.52	2050
WNRA (New York) ..	9.855	30.43	0000, 2000	Newfoundland			
WLWK (Cincinnati) ..	11.710	25.62	1500, 1730, 2000	VONH (St. John's) ..	5.970	50.25	2315
WRUW (Boston) ..	11.730	25.57	1200, 1730	Palestine			
WRUS (Boston) ..	11.790	25.44	1200, 1300, 1730	Jerusalem ..	11.750	25.53	1615
WCRC (Brentwood) ..	11.830	25.36	1500	Portugal			
WGEA (Schenectady) ..	11.847	25.32	1730, 2000	CSW6 (Lisbon) ..	11.040	27.17	2000
WOOW (Wayne) ..	11.870	25.27	1200, 1500, 1730	Spain			
WRCA (New York) ..	11.893	25.22	2000	EAQ (Aranjuez) ..	9.860	30.43	2050†
WNRI (New York) ..	13.050	22.99	1500, 1730, 2000	Sweden			
WLWLI (Cincinnati) ..	13.022	23.04	1200, 1300	SBU (Motala) ..	9.535	31.46	2220
WNRX (New York) ..	14.560	20.60	1500, 1730, 2000	SBP ..	11.705	25.63	1700
WNBI (New York) ..	15.150	19.80	1500	Switzerland			
WOOC (Wayne) ..	15.190	19.75	1200, 1500, 1730	HER3 (Schwarzenburg) ..	6.345	47.28	2050
WBOS (Boston) ..	15.210	19.72	1200, 1500, 1730	HER4 ..	11.775	25.48	2050
WLWL2 (Cincinnati) ..	15.230	19.69	1200, 1300	Berne ..	10.340	29.00	0200, 2045
WLWO (Cincinnati) ..	15.250	19.67	1730, 2000	Syria			
WCBX (Brentwood) ..	15.270	19.65	1200, 1500, 1730	FXE (Beirut) ..	8.035	37.34	1735
WGEO (Schenectady) ..	15.330	19.57	1200, 2000	Turkey			
WRUA (Boston) ..	15.350	19.54	1200, 1300, 1730	TAP (Ankara) ..	9.465	31.70	1800
WRUW (Boston) ..	17.750	16.90	1730	U.S.S.R.			
WRCA (New York) ..	17.780	16.87	1500, 1730	Moscow ..	6.230	48.15	0015, 1800, 1900, 2000, 2200
WCBN (Brentwood) ..	17.830	16.83	1300, 1500	..	6.770	44.30	0015, 2347
WNRA (New York) ..	18.160	16.52	1500, 1730	..	6.980	42.98	0015
Australia				..	7.300	41.10	0015, 0100, 0200, 1800, 1900, 2000, 2100, 2200, 2300, 2347
VLI4 (Sydney) ..	7.240	41.45	1515	..	9.480	31.65	0100, 0200
VLG (Melbourne) ..	9.580	31.32	1515	..	10.445	28.72	0730, 1240
Belgian Congo				..	11.634	25.79	1240
Leopoldville ..	15.167	19.78	1200	..	11.830	25.36	0015, 1200, 1240, 1320
Brazil				..	11.950	25.11	0015, 0100, 0200
PRL8 (Rio de Janeiro) ..	11.715	25.61	2030†	..	12.260	24.47	1220, 1600
China				..	15.530	19.32	0015, 1200, 1240, 1320
XGOY (Chungking) ..	9.635	31.14	0015, 1400, 1500, 1600	Vatican City			
Ecuador				HVJ ..	5.970	50.25	2015
HCJB (Quito) ..	12.455	24.09	0000, 2030	Athlone			
Egypt				..	Kc/s	Metres	
Cairo ..	7.510	39.94	1845, 2100	..	565	531	1340, 1845, 2200,*
French Equatorial Africa				..			2210†
FZI (Brazzaville) ..	11.970	25.06	1945, 2145				
India							
Delhi ..	6.190	48.47	0800, 1550				
..	7.240	41.44	1550				
..	7.290	41.15	0800, 1300, 1550				
..	9.590	31.30	1300				

It should be noted that the times are BST—one hour ahead of GMT. * Sundays only. † Sundays excepted.

RADIO ENGINEERING EDUCATION

A Plea for More Training "on the Job"

By THOMAS RODDAM

IN the last two or three years there has been a spate of reports on the Education and Training of Engineers. They derive from a desire to cash in on the prestige and publicity which the war has brought to applied science. Most of the proposals made are rather depressing, for they aim, though they do not say so, at the creation of a class of dissatisfied semi-intellectuals, machine-slaves with no breadth of outlook and no roots in any kind of civilised society. If such proposals are accepted, Fascism will have scored a spiritual victory: a purely technical education is a preparation for war, not a training in the art of living. Further, the best technicians are not the products of a purely technical training; contentment is essential to good work.

The spirit which has led to the present demand for reform has flourished in the past. In 1726 an excellent description* of our state was given: "... certain persons went up to the capital either upon business or diversion; and after some months continuance came back with a very little smattering in mathematics, but full of volatile spirits, acquired in that airy region. That, those persons upon their return, began to dislike the management of everything; and fell into schemes of putting all arts, sciences, languages and mechanics upon a new foot. To this end, they procured a royal patent, for erecting an academy of projectors in —: and, the humour prevailed so strongly among the people, that there is not a town of any consequence in the kingdom without such an academy. In these colleges the professors contrive new rules and methods.

"The only inconvenience is, that none of these projects are yet brought to perfection; and, in the meantime, the whole country lies miserably waste; the houses in ruins, and the people without food or cloaths."

This may be our warning: the

* "A Voyage to Balnibarbi" : Jonathan Swift.

critics of our industrial training system are setting up their academies. They are demanding vast sums of money and huge armies of men; and the houses are in ruins. Yet, while all this goes on, I cannot see that the old system has proved so ineffective. Radar and Merlin engines are not products of the polytechnics: the Mosquito and the Lancaster were not designed in huge Government colleges. Thomson, Rutherford, Lodge, Heaviside; no night school has produced men like these. Some critics base their proposals on dreary statistics of education in other countries. Not only is their reasoning misleading, but it is also unnecessary. We in this country are the heirs both of the European tradition and of the Industrial Revolution: we cannot march surely in the van of post-war prosperity if we peer anxiously round to study the progress of other countries which lack our long and continuous history.

Better Status Wanted

The planners will admit that we have our great men; they cannot do otherwise. But they talk about "mute, inglorious Miltons" and about training the rank and file. I do not believe in "mute, inglorious Miltons." They are not mute for long, nor can glory be denied them. The rank and file are our real problem. They are the bright young men who can be found in clumps here and there about the countryside. It is difficult to understand why so many of them elect to become engineers when they may choose more profitable careers. If a graduate is to start at £300 a year as a schoolmaster, and at £150 a year doing research, I can foresee a closed system of schoolmasters teaching boys to be schoolmasters, with only a little parasitic radiation reaching the outside world. It is still more profitable to auction pigs in a country market than to do radio research: the social

standing of a village G.P. who cannot even diagnose a broken rib is higher than that of a research worker in industry. Yet the G.P.'s technical knowledge of his trade is comparable with that of the keeper of the village bicycle-shop who charges batteries and fits new valves to our sets. The first step in any drive to encourage engineers must be an increase in their incomes and an improvement in their status. We must stop calling Mr. Bob Sawyer, M.B., Doctor Sawyer, a title to which he has no claim, and we must call Bill Sodderit, Dominus Sodderit, Magister Sodderit or Engineer Sodderit, depending on his qualifications.

So much for fundamentals. Now let us turn to the radio industry and see what sort of people we need. First we must have the inventing engineer, the practicalising engineer and the producing engineer; they need their satellites, junior engineers, computers, mechanics, wiremen. Then we want skilled mechanics and draughtsmen in the factory. We want the low-skill workers at the benches on production runs, the inspectors, the rate-fixers, the chasers, the storekeepers and all the ancillary services of a factory.

The education of all these men, up to the school-leaving age of 15 or 16, should not be technical. It should be a healthy liberal education; mathematics and history, physics and geography, the literature of the child's own country and the language of two others. Technical education for the young should be restricted to ballet dancers, who are not intending to follow their trade until they retire at the age of 60. If this course is adopted, there will be a need for more secondary schools, but there will be a balanced increase in the educational level. We shall then have an output of moderately civilised young animals, who should be capable of reading and writing in a fairly competent way, with some knowledge of the fundamentals from which their work, whatever it may be, derives.

Radio Engineering Education—

Furthermore, the choice of a career is postponed to an age where a reasonable decision can be made. It is unfair to demand such a decision when the child enters a post-elementary school.

At this stage the fully formal education of the majority will stop. It is up to industry to decide what happens next. In my view, the solution is a rather old-fashioned one: the boy gets a job in a factory and works there. He starts off as a messenger in the drawing office or the stores. He gets used to the new discipline of factory life, he learns his way about the place, and he sees what goes on. After a few months he transfers to the bench, and learns to operate the simpler machines. Once he has settled in, he should receive some part-time training, during working hours, both in drawing office practice and in the fundamentals of machines and materials. After his period at the bench he is transferred to the drawing office, to do tracing and the simpler detailing work. This proposal, of course, assumes that there is no overwhelming reason why the trainee should stay either in one shop or in the drawing office: some flexibility is essential in any scheme. The average trainee, however, will pass through both workshops and drawing office; at 18 he should therefore have acquired an adequate general education and a basic trade training which will enable him to decide what is his particular talent. At this stage he can settle down to develop into a skilled mechanic or draughtsman, with an ultimate hope of becoming either a works manager or a chief designer if he is good enough.

It will be noted that most of the training is actually given on the job itself: a few lectures or formal demonstrations may be given each week, during working hours; fewer may be given at night. The formal training must be given by men actually in close contact with factory practice.

Now for our aristocracy. The Old Men of radio in general had no university or polytechnic training; they started, thirty or forty years ago, with keen minds, to find out what went on. They made jiggers; they made billi condensers; they held matches under the bulb-tips of their valves to

increase the gas content; they melted candles to make condensers; they went to the far corners of the earth and put up aerial masts; they made sets and they made them work. Many of them, as they worked, discovered that they did not know enough mathematics, or physics. They read, and they made sets work better. The next generation came from the universities; they were physicists or engineers or mathematicians, and they carried the theoretical work a stage forward.

Poorly-trained Recruits

A new generation is now appearing in the laboratories. There are still the few who have the radio thumb, who in spite of a lack of formal education can persuade circuits to work; there are still the few who have been trained as scientists, and who are now applying the scientific method to radio problems. But a large proportion of to-day's recruits are coming from the polytechnics and from Hankey courses in the universities. The training in these places leaves much to be desired; it is a purely trade training, an unbalanced forcing of a restricted technical talent. Nor is it a good trade training: it is often only too clear that polytechnic staffs are of very poor quality, that their limited knowledge is inaccurate and outmoded. I can sympathise with them in their difficulty in keeping up to date in the sterile atmosphere of the polytechnics; often, however, it is not merely opportunity which has been lacking. If there is no talent to staff our present polytechnics, how then can we hope to staff all these new academies which are planned. Polytechnics are a politician's solution and must be rejected. Polytechnics and cinemas are our modern bread and circuses.

If we reject polytechnics and yet demand a formal advanced education, where can we find it? The advanced education which will give us what we want has already an approximate solution in one provincial university. Here many students spend their first year reading mathematics, followed by two years reading physics. I would modify this, so that the concentration on rather abstract theoretical physics was reduced, and introduce a two-

year course for a physics-mathematics tripos with a little elementary engineering as a common feature with the Mechanical Science tripos first year. This would be followed by a simplified version of what is now, I believe, Part III of the mathematical tripos. I have met few engineers who knew enough mathematics.

The reader may think that this is all very reactionary: I have divided wireless workers into two classes—artisans and aristocrats—and I have shown no bridge between them. Remember before you condemn this scheme that *aristo* has not always been a term of praise: remember that in all branches of learning we must enable the book-clever to receive a university education whatever the family income. I do not wish to label a boy "working-class"; I wish to label him "hands better than head," and I wish to prevent him being swindled, to prevent him wasting, at a bad polytechnic, time which would make him a skilled craftsman if he were at the bench. If he lacks talent, a second-rate training will fit him for nothing: too old to be an apprentice, too specialised and academic to be happy as a semi-skilled worker, incapable of original work; education has its blind alleys. Only an education devoted to a true sense of values is of real use.

The boy whose intellect develops late will always be unlucky in any scheme of education. If, however, he has powers of leadership and a grip for administration, he will make his way from the bench to a job as shop superintendent, with a final prospect of becoming a works manager. From the drawing office he may become a designer. It would be ridiculous to base educational reform on a requirement that even the most stupid should be trained to do research.

I have given above my views on education: the reader will see that they are not the fashionable views. I have given also my reasons. The reader will be aware that there have been many articles and papers on this subject in the last year or so. Why? The official answer is that the Government has realised that there is something lacking in our technical education and wishes to remedy this situation. This, if

true, would be laudable, but there is every reason to believe that it is not true. An A. Sc. W. † Memorandum shows only too clearly that the Government establishments are not interested in providing educational facilities for their own staff. If the State will not even educate its own employees, how can we believe that it wishes to educate everyone? If the State pays Treasury clerks more than scientists, why should we swallow Ministerial plati-

† "Part-time Scientific and Technical Education." Association of Scientific Workers, London. 3d.

PART-TIME EDUCATION

I.E.E. Report on "Extension" Courses

A SUGGESTION that provision should be made for the education of three distinct groups of technical personnel: the craftsmen, the technicians and the professional engineers, is made in a Report recently issued by the Institution of Electrical Engineers. A few craftsmen's courses are already in existence but these will have to be expanded when as required by the new Education Act, part-time day release is compulsory for all employees up to the age of 18.

It is suggested that there should be a three-year course for a craftsman certificate, followed by a more general course, lasting two years, in workshop administration. Radio mechanics are specifically mentioned as a class for whom a specialised third-year course might be made available. For the technicians' group, which includes technical assistants, testers, designer-draftsmen and erection engineers, it is proposed that the existing course for the Ordinary National Certificate in Electrical and Mechanical Engineering should be co-ordinated as a basic course and that this should be followed, where necessary, by a course in advanced technology of a type which has already been developed by the City and Guilds of London Institute.

One of the most important suggestions is that pupils who do well in the first two years of the course for the Ordinary National Certificate should be combined with those who have reached the standard of a good school certificate

tudes? I seem to hear a voice saying: "Education, like the Ritz Hotel, is open to all," and those who haven't any money can have sausages and swipes at the British Polytechnics. If I can't have chicken casserole in Cambridge, I would rather have bread and cheese and beer at the bench: Cheshire cheese, not some synthetic stuff with glittering tinfoil round it. There is an awful danger that we are about to do the wrong thing for the wrong reason. Technical education does not breed technicians; a change of outlook will.

in Mathematics and Physics and that together these students should enter a two-year course leading to an Intermediate National Certificate which would be designed to meet the requirements of the Section A examinations of the Institutions of Civil, Mechanical and Electrical Engineers. These courses would lead to the Higher National Certificates in Electrical Engineering and kindred subjects.

Stress is laid on the necessity for the provision of additional technical teachers and on the value of "sandwich" courses for the education of employees who are not able to attend part-time day or evening classes.

A section of the Report contains proposals for the benefit of those whose education and training has been interrupted by war service in the Forces.



LAST - WAR VALVE. This type of valve was widely used towards the end of the 1914 - 1918 war. The filament operated on 4 volts and anode voltages of from 120 to 160 were used. Though normally mounted in a 4-clip holder, the valve was often used with an adaptor, as shown, for insertion in a standard 4-pin "R" valve socket.

GALPINS

ELECTRICAL STORES

"FAIRVIEW,"
LONDON ROAD, WROTHAM,
KENT.

TERMS: Cash with order. No C.O.D.
All prices include carriage or postage.

ELECTRIC LIGHT CHECK METERS, first-class condition, electrically guaranteed, for A.C. mains, 200/250 volts 50 cy. 1 phase 5 amp. load, 11/- each.

SOLID BRASS LAMPS (wing type), one-hole mounting, fitted double contact, S.B.C. holder, and 12 volt 16 watt bulb. 4/-.

TUNGSTEN CONTACTS, 1/2 in. dia., a pair mounted on spring blades, also two high quality pure silver contacts, 1/2 in. dia., also on spring blades, fit for heavy duty, new and unused. There is enough base to remove for other work. Set of four contacts, 4/-.

RESISTANCE UNITS, fireproof, size 10 x 1in. wound chrome nickel wire, resistance 2 ohms to carry 10 amps. 2/6 each.

SWITCH FUSE in wrought iron case, 3-way, for 400 volts at 40 amp. 45/-.

ROTARY CONVERTER, input 40 volts D.C., output 75v., 75 mA, A.C., also would make good 50v. motor or would generate. 22.

AUTO TRANSFORMERS. Step up or down tapped 0-110-200-220-240; 1,000 watts. 25.

POWER TRANSFORMER, 4kW, double wound, 400 volts and 220 volts to 110 volts, 50 cycle, single phase. Price 220.

AUTO TRANSFORMER, step up or step down 500 watts, tapped 0-110-200-220-240 volts. 23 10s.

1/2 WATT WIRE END RESISTANCES, new and unused, price per doz., 5/-, our assortment.

MOVING COIL AMPMETER by famous maker, 2in. dia., flush mounting, reading 0-10 amps., F.S.D., 20 M/A, price 27/6.

SEARCHLIGHT, by famous maker, size 22in. dia., 18in. deep, complete with cradle, reflecting mirror 20in. dia., for electric bulb fitting, no bulb, adjustable focus, glass front, price 27 10s.

AMPLIFIER COMPONENTS from dismantled American 10 and 20 watt amplifiers, all metal cases and compound filled.

INPUT TRANSFORMERS, ratio 12 to 1, centre tapped, price 15/-.

P.P. OUTPUT TRANSFORMER, ratio 6.2 to 1, centre tapped, price 10/-.

POWER TRANSFORMER, pri. 95/100 v., sec. 280-0-280 at 80 M/A, also 5 v. at 3A, price 12/6.

LARGE TRANSFORMER, size 9 x 8 x 5in., weight 34lbs., condition as new, input 10-0-200-220-240 volts; Output 10-0-56-58-60-62-64 volts, at 15 amps., by famous maker. Price 27 10s. carr. paid.

METAL RECTIFIERS, size 14 x 3 1/2 x 3 1/2 in., output 50v., 1 amp., 35/-; another 5 1/2 x 2 1/2 in., output 100v.-250 M/A, 17/6; another 200v-50 M/A, 10/-.

CABINET LOUDSPEAKER, for extension only, 5 watt output, 8in. dia. cone, high quality, size of cabinet 16 x 14 x 8 1/2 in. x 1/2 thick, cabinet slightly marked at top, price 23.

SMALL M.L. ROTARY CONVERTER, in cast ali. case, size 14 x 4 1/2 x 4 1/2 in., permanent magnet fields, converters need attention, not guaranteed, 30/-.

MOVING COIL AND M.I. METERS,
FOR FULL DETAILS OF ABOVE AND OTHER
GOODS, SEND FOR LIST, 2d.

Single-valve

MODULATED TEST OSCILLATOR

A Cheap and Compact Instrument with a Range of 250 kc/s to 15 Mc/s.

SOME time ago it was decided to see if a cheap and compact signal generator could be produced using only one valve, and using easily obtainable parts. Naturally, it was not possible to produce anything like a sub-standard instrument, but the final result is a useful piece of equipment for many purposes. RF and IF frequencies from 15 Mc/s down to 250 kc/s are available modulated or unmodulated, and an audio frequency may also be obtained.

Circuit.—The valve used is a 6A8G heptode frequency changer. This valve has a negative mutual conductance between the signal grid and the oscillator anode. A transitron RF circuit was therefore chosen using these electrodes. This allows the use of untapped coils, and simplifies range switching.

Three ranges of frequency were chosen as follows:—

Range 1.—250 kc/s to 750 kc/s.

Range 2.—700 kc/s to 2,000 kc/s.

Range 3.—5 Mc/s to 15 Mc/s.

By K. W. MITCHELL, B.Sc.

These ranges cover most requirements, and the use of harmonics allows continuous coverage up to more than 30 Mc/s. If desired, a lower frequency range than Range 1 could be added, using a long-wave tuning coil. Coils suitable for the ranges given may be made as follows:—

Range 1.—800 μ H, 200 turns of 34 SWG enam. wire close wound on a 1½ in. former.

Range 2.—100 μ H, 100 turns of 34 SWG enam. wire, close wound on a ¾ in. former.

Range 3.—2 μ H, 15 turns of 22 SWG enam. wire wound on a ¾ in. former spaced to occupy 1 in. length.

Range switching requires a single-pole 3-way switch, and tuning is by a 0.0005 μ F variable condenser.

A low output impedance was chosen to simplify the construction of the attenuator, and an RF transformer is used in the anode circuit of the valve. A screened all-wave RF choke was obtained, and one of its winding sections

isolated and used as the secondary winding of a transformer. The remainder of the choke then becomes the primary winding, and a step-down ratio of about 10 or 15 to 1 is obtained. The section used as the secondary should be at the HT end of the choke to avoid capacity coupling to the anode lead.

Attenuator.—The attenuator may be quite simple, and may be assembled as shown in the diagram. Each section is screened from the next, and screened leads are used to connect the tapping points to the coarse attenuator switch. This switch should be of the low-capacity type if possible, or the minimum output obtainable may be rather large, especially at the higher frequencies. Composition carbon resistances are very suitable for the attenuator network. A blocking condenser is included in the output lead in case the signal is accidentally applied to a point of high voltage. This condenser should be completely screened, and to ensure freedom from stray pick-up, the whole instrument should be in

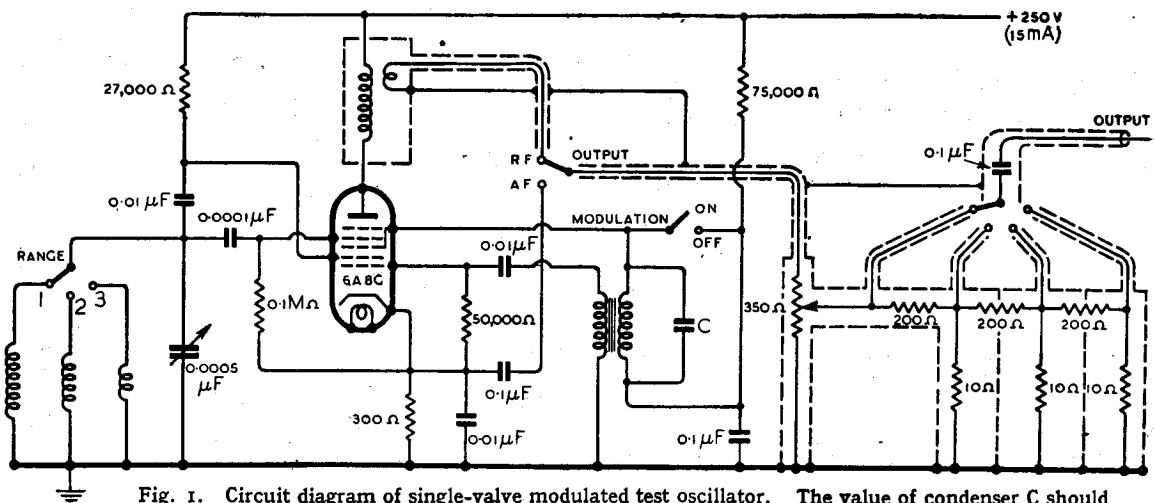

Fig. 1. Circuit diagram of single-valve modulated test oscillator. The value of condenser C should be chosen to give a convenient AF note with the transformer used.

an earthed metal box, with RF filters in the power supply leads.

Audio-Frequency Oscillator. — The AF side of the generator uses a back-coupled circuit connected between the screen and the oscillator grid. An old intervalve transformer is very suitable for this, and the pitch of the note obtained may be adjusted by connecting a suitable condenser across one of the windings. This condenser should not be too large or the circuit will fail to oscillate. Modulation is switched on

750 kc/s (545-400 m.), since most sets will receive these frequencies. The gap may be bridged by picking up the second harmonic of the generator output. The frequencies 350-550 kc/s will have their second harmonics from 700-1,100 kc/s (429-273 m.).

Range 2.

From 700-1,500 kc/s (429-200 m.) may be calibrated directly against the medium-wave band. The remainder must be done on the short-wave band using harmonics of the generator

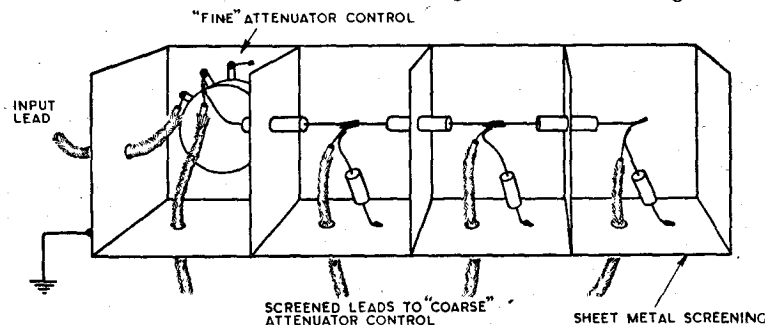

Fig. 2. Construction of the attenuator. An "L"-shaped cover should be made to enclose the two open sides of the screening assembly.

and off by a shorting switch across the HT side of the transformer. Screen voltage should be kept down to a value about half that of the oscillator anode, or it may be found that the RF oscillator only oscillates when the modulation is switched on. Depth of modulation tends to be excessive with this circuit, but may be adjusted to some extent by adding a damping resistance to the AF transformer. For most purposes, however, the degree of modulation is not very important. An audio frequency output may be taken from the cathode circuit, a small resistance being included for this purpose. The cathode bypass condenser serves to remove RF from the audio output.

Calibration.—Before attempting to calibrate the ranges fully, make sure that the output frequencies are approximately correct by checking one or two points. An all-wave receiver which is known to be fairly accurately scaled is the easiest standard to check against, and may also be used for the final calibration.

Range 1.

Direct calibration may be used for the portions 250-350 kc/s (1,200-860 m.) and 550-

output, as follows: Tune in a harmonic of 1,500 kc/s, the fourth at 6 Mc/s (50 m.) will do well. Alter the receiver tuning slowly towards the higher frequencies and change the generator tuning at the same time so that the receiver and generator "keep in step." When the receiver tuning is 6.4 Mc/s (46.9 m.), the generator output will be 1.6 Mc/s. Continue moving the receiver and generator together until the receiver tuning is 6.8 Mc/s (44.1 m.). The generator fundamental frequency will now be 1.7 Mc/s. In this way the remainder of the range may be calibrated.

Range 3.

This range may be calibrated directly against the short-wave range, except for a small portion near 5 Mc/s (60 m.), which can be done by using its second harmonic (10 Mc/s, 30 m.).

Notes. — Before winding the coil for Range 1, see if there is an old coil from a 465 kc/s IF transformer about. It would quite likely do.

It has not been possible to try valves other than that specified, but it seems likely that any type of heptode frequency changer having a similar internal construction could be used.

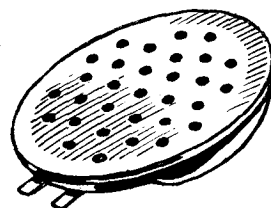

H.A.5 DEAF-AID CRYSTAL MICROPHONE

ASTATIC will be ready to serve you again with high quality piezo-electric devices when the 'All-Clear' of Victory sounds. Astatic deaf-aid microphones can be supplied only if Import Permits are established. Model H.A.5 illustrated is used as standard by America's leading hearing-aid instrument makers.



THE ASTATIC CORPORATION
CONNEAUT, OHIO, U.S.A.
and
TORONTO, CANADA.

—Exclusively Represented by—
Frank Heaver Ltd. Kingsley Road
Bideford, N. Devon

CRONAME
RADIO COMPONENTS

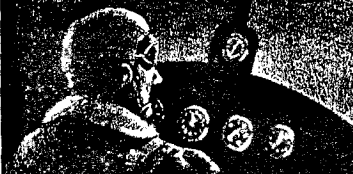

MMILITARY demands on the electronics industry require large quantities of material made to precision standards never before approached by quantity production methods. Crowe has had signal success in solving problems of rapid production of precise electronics control mechanisms. This experienced ability will be an important factor in the post-war programmes of many firms.

*
Exclusively Represented in Great Britain by
FRANK HEAVER LTD.
Kingsley Road, Bideford, N. Devon.

CROWE NAME PLATE AND MANUFACTURING CO.
CHICAGO, ILL. U.S.A.

Letters to the Editor

Peacetime Uses for V2 • FM Protection Against High-Amplitude Interference Pulses • Bad Books

V2 for Ionosphere Research?

ONE of the most important branches of radio physics is ionospheric research and until now all our knowledge of conditions in the ionosphere has been deduced from transmission and echo experiments. One of the more modest claims of the British Interplanetary Society was that rockets could be used for very high altitude investigations and it will not have escaped your readers' notice that the German long-range rocket projectile known as V2 passes through the E layer on its way from the Continent. If it were fired vertically without westward deviation it could reach the F₁ and probably the F₂ layer.

The implications of this are obvious: we can now send instruments of all kinds into the ionosphere and by transmitting their readings back to ground stations obtain information which could not possibly be learned in any other way. Since the weight of instruments would only be a few pounds—as compared with V2's payload of 2,000 pounds—the rocket required would be quite a small one. Its probable take-off weight would be one or two tons, most of this being relatively cheap alcohol and liquid oxygen. A parachute device (besides being appreciated by the public!) would enable the rocket to be re-used.

This is an immediate post-war research project, but an even more interesting one lies a little farther ahead. A rocket which can reach a speed of 8 km/sec parallel to the earth's surface would continue to circle it for ever in a closed orbit; it would become an "artificial satellite." V2 can only reach a third of this speed under the most favourable conditions, but if its payload consisted of a small one-ton rocket, this upper component could reach the required velocity with a payload of about 100 pounds. It would thus be possible to have a hundred-weight of instruments circling the earth perpetually outside the

limits of the atmosphere and broadcasting information as long as the batteries lasted. Since the rocket would be in brilliant sunlight for half the time, the operating period might be indefinitely prolonged by the use of thermocouples and photo-electric elements.

Both of these developments demand nothing new in the way of technical resources; the first and probably the second should come within the next five or ten years. However, I would like to close by mentioning a possibility of the more remote future—perhaps half a century ahead.

An "artificial satellite" at the correct distance from the earth would make one revolution every 24 hours; i.e., it would remain stationary above the same spot and would be within optical range of nearly half the earth's surface. Three repeater stations, 120 degrees apart in the correct orbit, could give television and microwave coverage to the entire planet. I'm afraid this isn't going to be of the slightest use to our post-war planners, but I think it is the *ultimate* solution to the problem.

ARTHUR C. CLARKE,
British Interplanetary
Society.

Frequency Modulation

WHILE post-war plans for television and UHF sound broadcasting are under discussion, it is important that the pros and cons of FM should be understood. Space will not permit a full discussion here; but I wish to correct a misconception, found even among responsible engineers, that FM can give no protection against ignition noise or other similar pulses which have an amplitude much greater than that of the signal carrier. The actual response of an FM receiver to very powerful impulsive interference can be summarised as follows:—

(1) In the absence of a signal,

the FM receiver gives no output from impulsive interference.

(2) In the presence of an unmodulated carrier to which the FM receiver is accurately tuned, the impulsive interference causes no audible output. If the receiver is not accurately tuned, there will be an audible output, but the amplitude of the pulses in the audio-frequency circuits of the receiver will correspond to a modulation of the carrier of less than 100 per cent., in fact to a modulation depth equal to the ratio of the frequency error in tuning to the frequency swing corresponding to full modulation of a frequency-modulated signal.

(3) In the presence of a frequency-modulated signal to which the receiver is accurately tuned, the audio-frequency noise pulses are limited to the *instantaneous* level of signal modulation. If the receiver is not accurately tuned, the amplitude of the audio-frequency pulses will be increased by the amount defined in (2) above.

If it is true, as sometimes suggested, that ignition noise is the chief trouble in UHF broadcasting, this summary provides a basis for the comparison of FM with other systems, such as wide-band AM with audio-frequency limiting.

D. A. BELL.

London, N.21.

"New Thoughts on Contrast Expansion"

EXPEDIENCY be damned. My condemnation of contrast expansion was not based upon noise and neighbour tolerances. John B. Rudkin (your January issue) says "condemn the Philadelphia Orchestra because it is too large to play in the village hall." The truth is that anyone who asks it to do so should be condemned, and those who try to get the B.B.C. Orchestra into their bedroom are committing a crime. If the room is small, acoustically small, then only a limited contrast is proper, and all music

should be chamber-ified. Conversely, in the Albert Hall, a string quartet deserves an expander.

There is an analogy in community singing: a soloist sings a chorus; the audience take it up, and they sing it at about half the speed. The soloist's tempo is all wrong for a large body of singers, and if the volume is unchanged as the result of an interposed electrical link the listener can still estimate, from tempo and contrast, the size of the audience.

THOMAS RODDAM.

War Surplus Disposal

I DISAGREE with L. E. J. Clinch (*Wireless World* for January) about allowing "enthusiastic amateurs" to buy radio tuff directly from war surplus stocks. What is an "enthusiastic amateur"? And if they have such privileges in radio, why not in other fields? His proposed concession would, if granted, lead to an economic disaster, since it would inevitably be followed by similar concessions to anybody and everybody.

There are sound economic grounds for claiming that the privilege should be confined to professionals. The term "professionals" includes, in my view, not only the big manufacturers, who can and will look after themselves, but also the smaller fry, including the humble research workers, designers and servicemen—on whose behalf I put forward my original plea. These professions produce for others—not, like amateurs, for themselves alone—and contribute vitally to "radio wealth."

Finally, I specified professionals of pre-war standing deliberately—with the very object of excluding those who, without adequate experience or proper training, have managed to pass as "professionals for the duration" under the unnatural conditions of war (e.g., a great many of the "servicemen" who have sprung up like mushrooms while genuine and competent servicemen were away in the Forces), and those who may be tempted, by "amateurish enthusiasm" acquired during the commercially riskless conditions of Service workshops, to set up as professionals after the war—with expensive disillusionment to themselves. Unless some such

line as "pre-war professionalism" is drawn, the door is open to all sorts of shady claimants who will only waste, or re-sell at exorbitant prices for no social benefit, the equipment so sorely needed by the small professionals.

W. H. CAZALY.

London.

"Pity the Poor Student!"

YOUR reviewer, T. R., is to be congratulated on his admirable work in the January issue of *Wireless World*. "Pity the poor student," indeed!

The rising tide of thoroughly bad books must give cause for alarm. One might suspect from the method of presentation and the style that the authors dash into print before they are sufficiently masters of their material; or that the production of such trash is undertaken as a rather lucrative hobby at the expense of earnest but untrained readers possessing a thirst for "short-cut" knowledge.

There is a pressing need for good basic textbooks, as your reviewer points out. Advanced mathematical techniques cannot be mastered in a few hours' desultory reading. The solid foundation of elementary mathematical work which must be assimilated before such techniques can be profitably applied is very considerable. I speak from experience.

There is no short cut to mathematical knowledge. It must be acquired by sheer hard work, hard thinking and constant practice on a wide variety of exercises until the various manipulations become second nature. In any subject, but more especially in mathematics, a sound basis is necessary on which to build the superstructure.

Let the aspirant make an end of these deplorable books and retrieve his Algebra, Trigonometry and Calculus. Let him embark on a year's hard grind at what he may know hazily or have completely forgotten. Let him work out to the bitter end all the examples. Let him keep notes of all he does. No matter if his notes are practically a copy of his textbook—if it is a good book.

Then, and not till then, let him try higher things.

A. M. HARDIE,
Squadron Leader,
Royal Air Force.

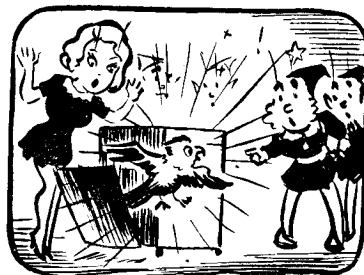

THE "FLUXITE QUINS" AT WORK

"Our wireless needs FLUXITE, that's clear, Those noises it makes are darn queer. Just hark at it now, That's bad language, I vow." "You're right," exclaimed OO, "look what's here."

See that FLUXITE is always by you—in the house—garage—workshop—wherever speedy soldering is needed. Used for over 30 years in Government works and by leading engineers and manufacturers. Of all Ironmongers—in tins, 8d., 1/4 & 2/8.

Ask to see the FLUXITE SMALL-SPACE SOLDERING SET—compact but substantial—complete with full instructions, 7/6.

TO CYCLISTS! Your wheels will NOT keep round and true unless the spokes are tied with fine wire at the crossings AND SOLDERED. This makes a much stronger wheel. It's simple—with FLUXITE—but IMPORTANT.

The FLUXITE GUN puts FLUXITE where you want it by a simple pressure. Price 1/6, or filled, 2/6.



ALL MECHANICS WILL HAVE

FLUXITE
IT SIMPLIFIES ALL SOLDERING

Write for Book on the ART OF "SOFT" SOLDERING and for Leaflets on CASE-HARDENING STEEL and TEMPERING TOOLS with FLUXITE. Price 1d. each.

FLUXITE LTD.
(Dept. W.W.), Bermondsey Street, S.E.1

RANDOM RADIATIONS

By "DIALLIST"

Why Call it Radar?

MANY of us hate the beastly word Radar and wonder how it ever came to be officially sponsored as a supplanter of the original highly satisfactory term. Radiolocation (though it may not appeal to linguistic pedants) is a good name, because it is descriptive. In six syllables it says concisely what this somewhat-before-the-war-baby of science is and does: Radiolocation is a method of locating things by radio. The term was invented in this country to denote systems developed by us for defence purposes in case we should be involved in war. Nobody invented radiolocation—like Topsy, it just grewed—but we were the first country to have practical working systems in being. Thanks to those who had foresight and faith in this new branch of wireless, reliable installations were in existence and in use when September 3rd, 1939, saw us plunged into war for the second time in twenty-five years. The basic principles of radiolocation were common knowledge to the scientific world long before 1939. The National Physical Laboratory at Slough was making daily use of them years before the war to measure the critical heights of the E, F₁ and F₂ layers, and observatories in other parts of the world followed suit. You will find the process described on pages 577 and 578 of the first edition (1932) of Terman's "Radio Engineering."

Providential

Other nations, no doubt, flirted with the idea of adapting the principle to warlike purposes: we alone got down to business. And it is providential that we did. The minute Air Force that we possessed when war came was heavily outweighed by the *Luftwaffe*. We were immediately open to attacks by air, against which our only defences were the AA guns and our few fighter aircraft. It was manifestly impossible to have every gun team at action stations for every minute of the twenty-four hours, or every fighter aircraft out on defensive patrol. Even AA gunners and fighter pilots must have some rest, and both guns and aircraft require the constant and thorough servicing that goes by the name of "care and maintenance." By giving early warning of the approach of hostile aircraft radiolo-

cation made these things possible—and just what that meant in the crucial days of the Battle of Britain anyone who participated in either role can tell with feeling. Radar is an American word. It is, one understands, a composite formed from RADio Detection And Ranging. American troops used it when they began to come over here in 1942 and we politely adopted it, just as we politely abandoned our Ack, Beer, Charlie, Don phonetic telephone alphabet, with all its last-war traditions, for Abel, Baker and so on.

□ □ □

Re-sorting Europe's Stations

WHEN this war is over one urgent task will be the re-sorting of European broadcasting systems and the putting of the whole business on a sound, workable basis. By September, '39, both the long waves and the medium assigned to broadcasting had become pretty chaotic. Mutual interference was rife, for there were far too many stations at work and there was far too much wavelength wandering. One trusts that there will be no delay about summoning a conference of broadcasting authorities and in getting out a plan fair for all which can be strictly enforced. Many stations will undoubtedly have to go—thanks to the attentions of our Air Force some of the unwanted appear to have gone already. Broadcasting is going to play such a vast part not only in the national life but in the international life of future years that we can't afford to let things slide. There will be something like a clean slate when peace returns, and the next European Broadcasting Conference is going to have a fine opportunity of doing really valuable work.

□ □ □

Training Engineers

SOME time ago Professor Willis Jackson read before the I.E.E. an important paper on the education and training of the telecommunication engineer. It was followed by a most interesting discussion, and others have since taken place at I.E.E. centres in different parts of the country. Of two things there can be no doubt: first that we are going to need telecommunication engineers of the highest class in increasingly large numbers; and

second, that the present training methods are by no means all that they should be. Professor Jackson's scheme is that after leaving school the budding T.E. should spend one year in industry, three years at a university, then a second year in industry and finally another year at a university in an advanced post-graduate course and in research work. To some that will seem a long period to spend in preparation for a career: the boy who left school at 16 would be 22 by the time he made a start in his profession. But it's not too long when you come to think of the surprising amount of ground that has to be covered nowadays by anyone who intends to become a fully qualified T.E. Such an engineer has certainly as wide a field of both theory and practice as the medical man. The shortest time in which a man can qualify in medicine is 5½ years; that is for a diploma—at least six years are needed for a degree—and in any event he should put in a further minimum of six months in a hospital appointment before practising.

The University Course

At the discussions I've mentioned everyone seemed agreed that the preliminary year in industry was a good thing and most people favoured the spending of another year in the same way after graduation. Where there was disagreement was over the nature of the university course. At present it tends to be too general. All electrical engineering undergraduates have much the same course, and the intending telecommunications expert has to spend (I don't like to write "waste") far too much time on such things as heat, steam boilers, the design of steel and concrete structures, and other subjects which belong to the mechanical rather than to the electrical engineer. In some university courses only a small fraction of the electrical engineering degree curriculum is devoted to telecommunications, and the time assigned to such vital ground work as mathematics, physics and chemistry is much too short.

What are Your Views?

It is extraordinarily difficult to devise a training scheme without bad snags. To me the three years at the university seems too short a time to qualify for an electrical engineering degree—though that must be intended, for the later fourth year is styled "post-graduate." Here's a tentative suggestion. The boy starts at 16 after passing the School Certificate, or whatever form of general examination is adopted in its stead should it be

abolished in its present shape. He then does a year in industry, and during that year, if he is bright, he also passes his first professional examination. At the end of three years at the university he may take the B.Sc. degree and also sit for a lower professional diploma in electrical engineering and corresponding roughly to the L.R.C.P. of medicine. For the B.Eng. degree in electrical engineering a fourth year at the university is required. Having done that year and a second practical year in industry he may take a higher professional diploma corresponding roughly to the medical M.R.C.P. The first industrial year and the first two university

years might cover the same ground for all would-be electrical engineers. In the third university year the paths of the intending T.E. and the intending power engineer diverge to some extent, a certain amount of specialisation being permitted. In the fourth university and second industrial years specialisation would be complete. The views of readers on this interesting and highly important subject would be welcome. One point, by the way, about the scheme I suggest is that, if he so wished, the student could break away and start out in life with a qualification of one kind or another at the end of his fourth, fifth or sixth year of training.

RADIO HEATING FOR MOSQUITO AIRCRAFT ACCESSORIES

THE time required for glueing the plywood covers fitted to jettison tanks for Mosquito aircraft has been reduced from 4 hours to 15 minutes by the use of radio-frequency heating. The accompanying photograph, taken in the works of John P. White and Company, shows two moulding fixtures for glueing these covers; that on the left is clamped down and "working." The top section of the "idle" fixture on the right is raised to show the strip electrodes through which the RF field is concentrated

making the two sections of unequal capacitance values it is possible, as in the present case, to concentrate extra heat on the part where curvature is most pronounced.

Between the two moulding fixtures can be seen the RF generator, a Pye Dielectric Heating Equipment Type 1, made by Pye Telecommunications, which has an output of 400 watts at 10 Mc/s. It employs two QY₂/100 pentodes in a push-pull circuit and has a matching range for "work" capacitances of between 20 to 400 $\mu\mu\text{F}$.

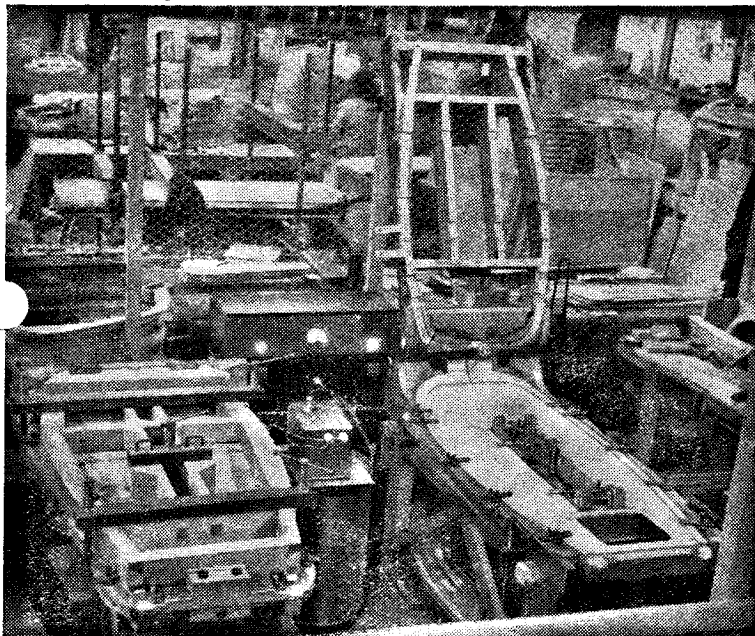

on the urea-formaldehyde glue lines. This electrode system is split into two sections, which are so connected that the "work" becomes effectively two condensers in series; thus the total capacitance of the "work" is reduced. Further, by

All the equipment, including the "work" fixtures, is housed completely in a wire netting cage to prevent the radiation of interference. A section of the netting was removed for the taking of this photograph.

VORTEXION

50 WATT

AMPLIFIER CHASSIS

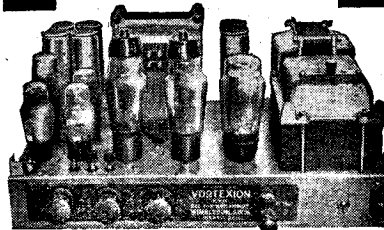

The new Vortexion 50 watt amplifier is the result of over seven years' development with valves of the 6L6 type. Every part of the circuit has been carefully developed, with the result that 50 watts is obtained after the output transformer at approximately 4% total distortion. Some idea of the efficiency of the output valves can be obtained from the fact that they draw only 60 ma. per pair no load, and 160 ma. full load anode current. Separate rectifiers are employed for anode and screen and a Westinghouse for bias.

The response curve is straight from 200 to 15,000 cycles in the standard model. The low frequency response has been purposely reduced to save damage to the speakers with which it may be used, due to excessive movement of the speech coil.

A tone control is fitted, and the large eight section output transformer is available to match, 15-60-125-250 ohms. These output lines can be matched using all sections of windings, and will deliver the full response to the loud speakers with extremely low overall harmonic distortion.

PRICE (with 807, etc., type valves) £18.10.0

Plus 25% War Increase

MANY HUNDREDS ALREADY IN USE

Supplied only against Government Contracts

VORTEXION LTD.
257, THE BROADWAY,
WIMBLEDON, S. W. 19.
Phone: LiBerly 2814

RECENT INVENTIONS

HIGH-FREQUENCY GENERATORS

ONE selected harmonic of a primary input frequency is developed by a valve which is adjusted to work as a Class C amplifier, that is, it is normally biased to cut off though the positive grid swing brings the anode current to saturation. Under these conditions, the grid is impulsed by a distorted waveform, and with a suitable input impedance the desired harmonic can be built up to large amplitude.

A filter circuit comprising a series inductance, and a capacitance shunted across the grid and cathode, allows sufficient primary voltage to reach the grid, whilst presenting a high impedance to the selected harmonic, looking back from the grid towards the supply. The cathode is in series with a blocking circuit which is tuned to the fundamental frequency, thus providing negative feedback as a further discrimination against that frequency. The output circuit is tuned to the desired conversion frequency.

Siemens Bros. and Co., Ltd.; M. Reed; and S. H. Moss. Application date February 16th, 1943. No. 562329.

GRAMOPHONE PICK-UPS

THE stylus S is coupled to a piezoelectric crystal C through a hollow transmission link T, which is filled with oil to damp out self-resonance, and is mounted to rotate between two rubber-lined collars B, B₁. One end of the

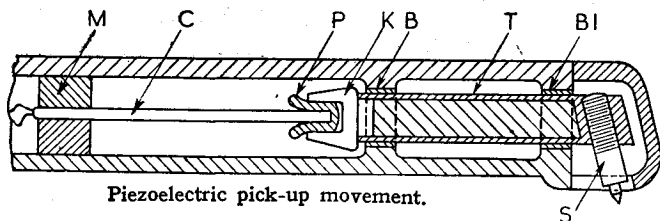

Piezoelectric pick-up movement.

crystal is coupled to the transmission link by being jammed, together with a piece of rubber packing, into a claw-shaped terminal K, the other end of the crystal being anchored to a block M set inside the outer casing. The stylus is mounted on the far side of both of the bearings B, B₁ and not between them, so as to reduce the effect of any non-torsional movements of the stylus upon the crystal.

Instead of driving a piezoelectric crystal, the axial rotation of the link T may be used to vibrate a soft iron armature between the pole pieces of an electromagnetic reproducer.

A. Schumann. Application date January 29th, 1943. No. 562803.

ANTI-FADING SYSTEMS

THE problem of frequency-selective fading has to some extent been solved by the so-called "diversity" system of reception, where the signals picked up by several widely spaced or differently orientated aerials are combined to the best advantage at a

A Selection of the More Interesting Radio Developments

common point. The object of the present invention is to secure the same favourable result by using only one receiving aerial.

Incoming signals are first converted to an intermediate frequency in the ordinary way, but the IF amplifier stage is split into three parallel branches, two of these being tuned to the upper and lower sidebands respectively, whilst the third is tuned to the converted carrier frequency. A tapping is taken from each of the sideband channels to a pair of balanced diodes where a gain-control voltage is developed and fed back to one or other of the sideband amplifiers as required. Meanwhile the output from the carrier-wave channel is equally divided between two coils, which are respectively coupled to coils carrying the regulated outputs from the two sideband channels. The two resulting currents are first separately rectified and are then combined to give a signal which is free from fading.

Marconi's Wireless Telegraph Co., Ltd. (assignees of De W. R. Goddard). Convention date (U.S.A.) September 12th, 1941. No. 562779.

balance when the machine is flying high. The out-of-balance current which is developed as the craft approaches the ground is rectified, amplified and smoothed before being fed to a calibrated ammeter.

The General Electric Co., Ltd., and D. M. Heller. Application date May 6th, 1942. No. 563469.

RECEIVER FOR FM SIGNALS

IT is possible to remove unwanted amplitude variations from a frequency-modulated signal, either by means of a limiter valve, or by a pair of balanced detectors. The limiter must, however, be run at saturation, which means using high gain; whilst, on the other hand, it is difficult to ensure that the detectors are accurately balanced over the full range of signal modulation.

As an alternative solution it is now proposed to detect separately any AM components that may be present, and to feed back the rectified voltages in anti-phase to the signal, so that they wipe out the original defect. For this purpose the incoming signals are passed to a pair of frequency-discriminating diodes, which are arranged not only to detect the required FM signals, as usual, but also to rectify separately any amplitude variations of the carrier wave. The two rectified outputs are fed to separate grids of a pentode modulator, which recombines them in such phase that the original amplitude modulation is cancelled out.

Marconi's Wireless Telegraph Co., Ltd. (assignees of M. G. Crosby). Convention date (U.S.A.) October 25th, 1941. No. 562702.

TRANSMISSION LINES

A TRANSMISSION line is usually loaded to reduce attenuation by inserting inductance coils at intervals along its length. This, however, reduces the velocity of wave-transmission to an extent which varies with different frequencies and so introduces a certain amount of distortion.

The invention consists in applying "negative-resistance" loading unit, which reduce attenuation by off-setting the ohmic resistance of the line, and also permit a higher transmission velocity to the lower frequencies, so as to maintain a uniform response over a wide frequency band.

A convenient form of loading device for this purpose is the so-called "Thermistor," which is a thermally sensitive semi-conducting mixture of manganese and nickel oxides, possessing a high temperature coefficient of resistance and a time constant which depends upon its physical dimensions. It can therefore be made to respond selectively to a given band of frequencies, say from 2 to 3 kc/s, for telephony, giving a negative-resistance response within this range, and a positive resistance or "cut-off" above and below. Alternatively, the same result can be secured by using back-coupled valves to apply negative resistance to the line, these being associated with impedance elements to control the cut-off, and with equaliser

ELEVATION INDICATORS

WHEN flying at a height below that at which a barometric gauge can be used, e.g., in making a blind landing, the inventors make use of the changes that occur in the impedance of an aerial which is radiating energy from the aircraft. The radiated waves must be at least four times as long as the maximum distance over which readings are to be taken, because at greater heights the aerial impedance passes through successive maxima and minima (as the elevation increases by quarter-wavelengths) and this makes further indications unreliable. A wavelength of 36 metres, for instance, will register changes of elevation accurately up to a maximum height of 30 feet. Means are provided for automatically warning the pilot against using the radio altimeter when flying at heights above the specified limit.

The aerial is mounted horizontally along the wings of the machine. It is coupled to one arm of a bridge circuit, the other arms of which are set to a

networks to regulate the frequency response.

Western Electric Co., Inc. Convention date (U.S.A.) April 25th, 1942. No. 563417.

NEGATIVE RESISTANCE DEVICES

A "THERMISTOR" is a semi-conducting mixture of selected metallic oxides, and has the property of altering its electrical resistance with changes of temperature. The control temperature may be that produced by passing a current directly through the "Thermistor," or the latter may be indirectly heated from a separate source.

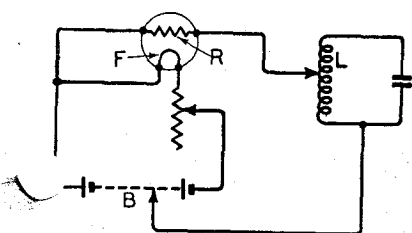

(a)

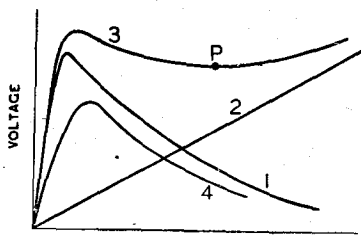

(b)

Negative resistance oscillator.

The invention relates to the use of such a thermally sensitive element for generating sustained LF oscillations, or for operating a filter or like circuit at a high "Q" value.

In diagram (a), a part of the inductance L of a resonant circuit is arranged in series with a "Thermistor" R, which is indirectly heated through a filament F from a battery B. The curve 1, diagram (b), shows how the voltage across the element R changes as the current increases, whilst curve 2 shows the ohmic or straight-line response of that part of the inductance L which is in series with R. (The curve 4 merely shows the effect upon the curve 1 of the steady biasing heat supplied from the battery.) The curve 3 is the resultant of curves 2 and 3, and shows that the system as a whole has a negative-resistance characteristic, and will generate oscillations when operated on or about the point P.

Standard Telephones and Cables, Ltd.; P. K. Chatterjee; and C. T. Scully. Application date January 8th, 1943. No. 562705.

The British abstracts published here are prepared with the permission of the Controller of H.M. Stationery Office, from specifications obtainable at the Patent Office, 25, Southampton Buildings, London, W.C.2, price 1/- each.

It's the hidden details that count

140 Daffes in production

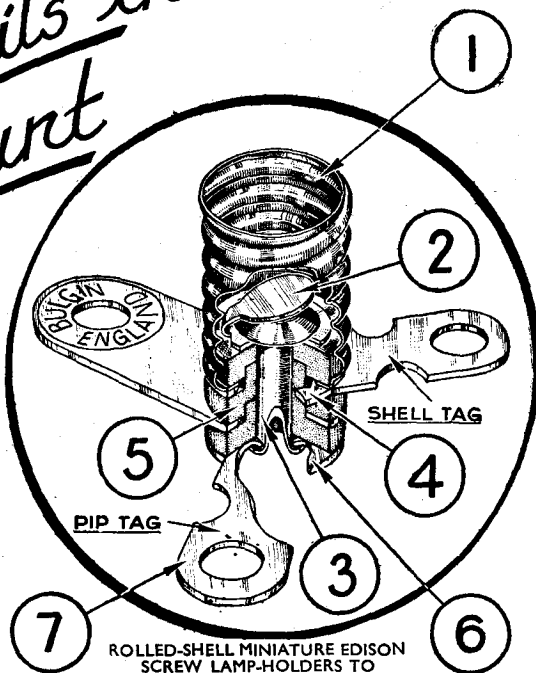

ROLLED-SHELL MINIATURE EDISON SCREW LAMP-HOLDERS TO B.S. 98/E.10.

- 1 — Threaded shell with dimensions and details to B.S. 98—10 mm. "MES" ; silver-plated finish.
- 2 — Central "pip"-contact of spring phosphor-bronze to ensure good contact ; silver-plated.
- 3 — Central rivet of solid steel ensuring permanently tight and positioned assembly.
- 4 — Locking teeth on "shell"-contact solder-tag, ensuring contact and preventing unintended rotation.
- 5 — Stepped insulant-washers preventing short-circuit and permitting comparatively high-voltage working conditions.
- 6 — Toothed solder-tag locks to rivet-turnover, fixing position and ensuring contact to "pip" -contact.
- 7 — Dual-purpose soldering tags coated pure tin and accepting "threaded" or "wound" wiring ; fixing bracket, normally "dead," may contact with shell and replace the "shell-tag."

THE CHOICE OF CRITICS



A. F. BULGIN & CO. LTD., BYE PASS RD., BARKING, ESSEX

The name "BULGIN" is registered Trade Mark)

UNBIASED

By

FREE GRID

Stroboscopic Speedometer

IT is astonishing how many and how diverse are the number of important "by-products" which have resulted from the invention and development of wireless communication. I refer, of course, to such things as radio therapy, electrical recording, public-address systems and all manner of other things which really owe their origin to wireless communications, for although the *deus ex machina* of all these things is the valve, it is safe to say that had radio communication not created an immediate and urgent need for a reliable device for amplifying the effect of minute changes of voltage, the thermionic valve might not have been invented for at least another half-century and we might have been spared the horrors of the raucous loudspeakers at our great railway termini.

Such "by-products" of radio as have been developed, however, are as nothing to what is brewing for us in the post-war world. An instance of what I mean is a device which has just been revealed privately to me by a high official at Scotland Yard as a thank-offering for his rise to his present position from that of a humble pavement pounder owing to the number of convictions for motoring offences which I gave him the opportunity of securing against me in the far-off days before the war.

This new device, which is designed to make the world still more unsafe for motorists, is startling in its simplicity. It uses neither valves, photocells nor anything of that nature, but employs a far more humble device, namely, the homely stroboscope. This device did not, of course, arise either directly or indirectly from radio; but, had it not been for the electric gramophone, which, of course, owed its development to the introduction of broadcasting, the stroboscope, by which those of us on AC measure and regulate the speed of our turntables, would certainly never have been brought to the fore.

We are, so I learn, to be compelled, after the war, to have metal discs covering the spokes of our car wheels and on these discs

will be painted stroboscopic segments corresponding to a speed of 30 m.p.h. Policemen will be provided with lanterns plugged into a convenient socket on the nearest street lamp post, all of which will be fed with frequency-controlled AC. It will obviously only be necessary for the post-war sleuth to shine his wretched lantern on to the wheels of a passing car to see at a glance whether or not it is exceeding the speed limit, without the necessity of stop-watches and other pre-war archaisms.

Horological Horror

SPEAKING as an old seafarer who sailed the seven seas in the days of the *Thermopylæ* and *Cutty Sark*, when ships were ships and not the evil-smelling mechanised monstrosities that they are to-day, I think it high time that a protest was made at the excessive bias which the BBC exhibits towards the Army and the Air Force at the expense of the seafaring fraternity in the matter of the horological jargon which it puts into the mouths of its announcers and announcettes in the Forces programmes.

Every time it occurs it fills me with insensate rage, and I feel like unshipping my peg leg like Long John Silver and beating the Board of Governors over their heads with it. No matter who it was that first thought of the idea, the governors must be held responsible, as that is what they get paid for. They take a perfectly respectable girl who has all her life been used to telling the time in a normal civilised manner and compel her to tell us that the next programme will begin at "Oh-two hours" or at "fourteen hours," leaving us unfortunate civilians who have not had the benefit of a military education to work out with a set of log tables what time they mean on the normal civilised clocks to which we are accustomed. I have managed to secure a 24-hour watch, but this has made confusion worse confounded,

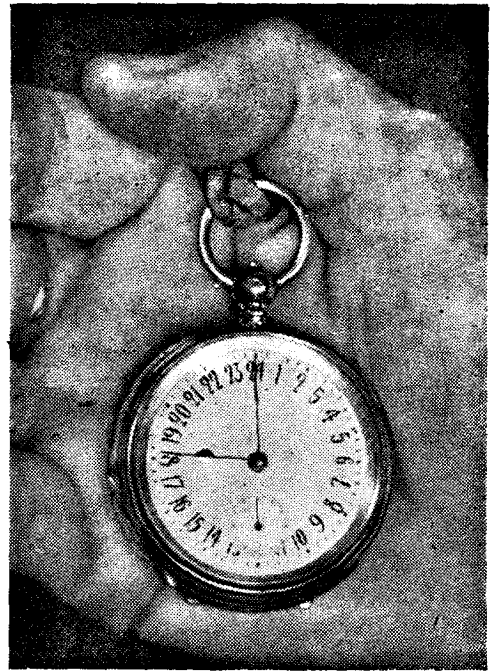

Confusion worse confounded.

for as you can see by the accompanying photograph, when it appears by the angle of the hands to show 9 o'clock it in reality indicates 6 p.m.

I am perfectly well aware that I shall get a spate of letters telling me of the manifold advantages of this method of reckoning time as compared with our normal "a.m." and "p.m." system. I gladly concede this point in advance, but in reply would say that if the BBC *must* muck about with the clock and try to go all scientific in their desire for horological exactitude why don't they go the whole hog and adopt a decimal system of reckoning time by dividing the day into ten hours or some multiple thereof.

But this is not my main point, which is the gross unfairness to seafaring men, whether they serve in the Navy or Merchant Service. Not the slightest attempt is made to meet their needs by using for announcements the method of reckoning time to which they are accustomed on board ship. Even in programmes of an exclusively nautical nature a gross insult is offered to seafarers by using their "Oh-two hours" tomfoolery instead of announcing it as "four bells in the middle watch."

I am particularly surprised at our merchant seamen putting up with it without protest. Of course, one can understand the attitude of Naval men with their tradition of being the "Silent Service."