

# Wireless World

Proprietors :  
ILIFFE & SONS LTD.

Managing Editor :  
HUGH S. POCOCK,  
M.I.E.E.

Editor :  
H. F. SMITH

Editorial, Advertising  
and Publishing Offices :  
DORSET HOUSE,  
STAMFORD STREET,  
LONDON, S.E.1.

Telephone :  
Waterloo 3333 (35 lines).

Telegrams :  
"Ethaworld, Sedist, London."



**PUBLISHED  
MONTHLY**

Price : 1/6

(Publication date 26th  
of preceding month)

Subscription Rate :  
Home and Abroad  
20/- per annum.

Radio and Electronics  
34th YEAR OF PUBLICATION

**MARCH 1945**

MONTHLY COMMENTARY .. .. .	65
RADIOLOCATION. II.—History of its Development By Dr. R. L. Smith-Rose .. .. .	66
A NEW VERSATILE TONE CONTROL CIRCUIT By G. N. Patchett .. .. .	71
CATHODE BIAS IN PUSH-PULL STAGES By W. T. Cocking .. .. .	75
RAILWAY COMMUNICATIONS .. .. .	79
SUNSPOT MINIMUM YEAR By T. W. Bennington .. .. .	81
FREQUENCY CONTROL IN RADIO HEATING .. .. .	82
TEACHING MATHEMATICS By J. J. Durack .. .. .	83
RADIO DATA CHARTS—18 Transmission and Phase Shift of RC Couplings By J. McG. Sowerby .. .. .	84
UNBIASED. By Free Grid .. .. .	86
WORLD OF WIRELESS .. .. .	88
LETTERS TO THE EDITOR .. .. .	91
RANDOM RADIATIONS By "Diallist" .. .. .	93
RECENT INVENTIONS .. .. .	96

Branch Offices :

COVENTRY :  
8-10, Corporation Street,  
Telephone : Coventry 5210.

Telegrams :  
"Autocar, Coventry."

BIRMINGHAM :  
Guildhall Buildings,  
Navigation Street, 2.

Telephone :  
Midland 2971 (5 lines).

Telegrams :  
"Autopress, Birmingham."

MANCHESTER :  
260, Deansgate, 3.

Telephone :  
Blackfriars 4412 (4 lines).

Telegrams :  
"Iliffe, Manchester."

GLASGOW :  
26B, Renfield Street, C.2.

Telephone : Central 4857.  
Telegrams : "Iliffe, Glasgow."



*As many of the circuits and apparatus described in these pages are covered by patents, readers are advised, before making use of them, to satisfy themselves that they would not be infringing patents.*

## "HYPERLOY"

### TRANSFORMERS AND CHOKES

A range of High-performance, space-saving Components designed to meet the most exacting requirements of modern Electronic and Communication equipments.

- Small in size
- Weighing only 2 oz.
- Meeting the most rigid Tropical Specification
- Easily mounted in any position
- Manufactured in a variety of windings to meet many diverse applications

★ Owing to wartime restrictions on supply of raw materials, it is not possible to supply Wearite Components for purposes other than those connected directly with the war effort.

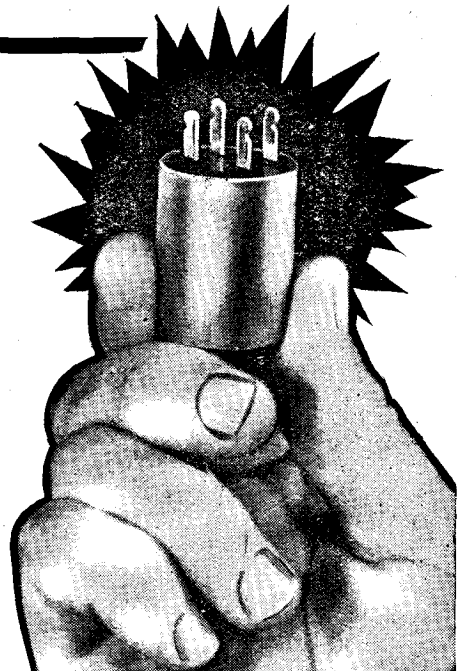

**WRIGHT & WEAIRE, LIMITED**  
HIGH ROAD, TOTTENHAM, LONDON, N.17 — Telephone: TOTtenham 3847-8-9

# MULLARD



## CATHODE RAY TUBES

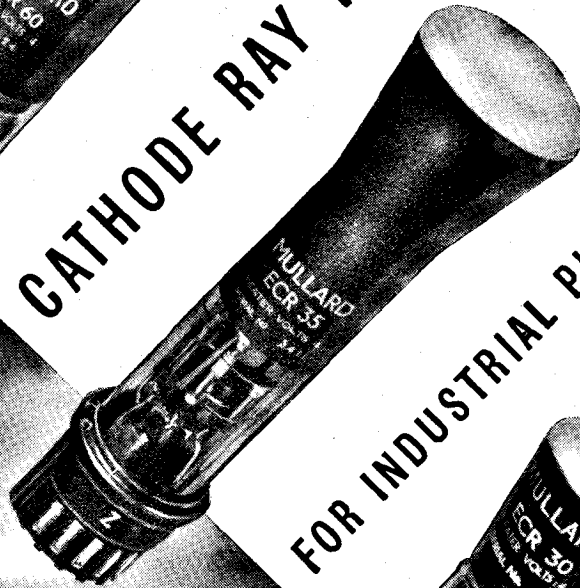

## FOR INDUSTRIAL PURPOSES

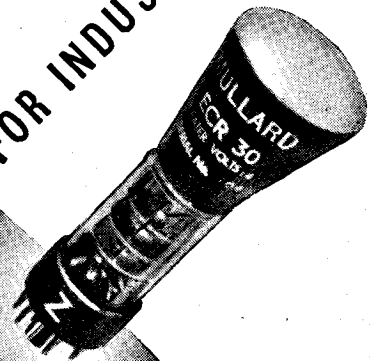

TYPE	SCREEN DIAMETER	LIST PRICE
ECR. 60	6"	£7. 7. 0
ECR. 35	3½"	£6. 6. 0
ECR. 30	3"	£3. 3. 0

# Wireless World

Radio and Electronics

Vol. LI. No. 3

MARCH 1945

Price 1s. 6d.

## Monthly Commentary

### Origins of Radiolocation

An article published elsewhere in this issue will, it is hoped, serve something more than its primary purpose of giving a simple account of the historical development of radiolocation. It should serve to emphasise the futility—or worse—of indulging in undignified wrangling over national priority in matters of scientific development and invention. Science tends ever to become more international, and developments are to an ever increasing extent built upon the foundations laid by workers of many lands. No longer does an important “invention” emerge fully fledged as an individual production.

Broadly speaking, that has been true throughout the whole half-century of radio. Readers may remember that, when its earliest history was debated in our columns a year or so ago, it was concluded that, building on the foundations laid by a German Jew working on the theoretical predictions of a Scotsman, the next significant steps in recognising and establishing electro-magnetic waves as a means of communication were taken by a German, a Russian, a Hungarian-American, an Englishman and an Irish-Italian. With a parent of such mixed descent, it is hardly likely that radiolocation, the offspring of radio, should be able to sustain claims for that racial purity so beloved of the *Herrenvolk*.

The initial ideas and also some of the technique of radiolocation were undoubtedly derived from methods of ionosphere research developed in England and the United States some twenty years ago. The principle of making use of reflections, thus established, was carried a stage further by employing it in U.S.A. for aircraft altitude indicators. The French “obstacle locator” was the first true “radiolocator” to be described publicly, but at the same time work was proceeding in this country on aircraft locators working on the reflected wave principle. To stern necessity, in the shape of threatened war, must be ascribed the fact that we had a working system of radiolocation ready to meet the onslaughts of the *Luftwaffe*.

Just as radio development in general has been largely an international affair, so important single

developments tend increasingly to become a matter of properly co-ordinated team-work. As Dr. Smith-Rose points out in his article in this issue, practical radiolocation came into being as a result of a carefully planned programme of research devised by the Radio Research Board rather than as the invention of any one or more individuals. Here we have a good example of the importance of fundamental research, conducted for no obvious or immediate gain. From it came the scientific basis of radiolocation as an unexpected bonus.



### The Radio Industry Council

It is a hopeful augury for the future that the Radio Industry Council, at its recent formal inauguration, celebrated the event by publicly drawing attention to the wartime achievements of the industry that it represents. Wireless is news to the British public, which is always ready to take an intelligent interest in the doings of the industry. Unfortunately, there has in the past been a lamentable failure to take advantage of this fact. Well-informed public opinion is worth cultivating, and this will doubtless become an important function of the R.I.C. By its constitution the R.I.C. is essentially a federating council for co-ordinating the interests of the four independent associations that it represents. These bodies, which between them cover manufacturing activities in all wireless and electronic fields, are The British Radio Equipment Manufacturers' Association, The British Radio Valve Manufacturers' Association, The Radio Component Manufacturers' Federation and The Radio Communication and Electronic Engineering Association.

At the inaugural luncheon some of the more spectacular wartime achievements of radio, including the dramatic part played by radiolocation at the Battle of Matapan, were made public for the first time. These achievements are enumerated on another page.

In the difficult years that lie ahead the tasks of the R.I.C. are likely to be arduous and exacting. But it has made a good start, and we wish it well.



# RADIOLOCATION

## II.—History of its Development

**T**HE possibilities of devising some method of detecting solid objects with the view of avoiding collisions at sea was probably in the minds of many people immediately after the tragic disaster to the liner *Titanic*, which steamed at high speed into an iceberg while crossing the Atlantic on her maiden voyage in April, 1912. After this date there were doubtless many inventions of so-called "iceberg detectors," some of which depended upon the aural detection of an echo resulting from sounds emitted from a horn, siren or other source on board the ship. Echo-sounding devices based on this principle have been described during the past twenty-five years or more, and have been developed to a high degree for depth sounding at sea and submarine detection purposes. It is not proposed to divert our attention here to this sphere of development, but to restrict our consideration to the use of electro-magnetic waves, albeit to those of wavelength corresponding to a radio frequency rather than in the visual portion of the spectrum.

**Radio Waves for Exploring the Ionosphere.** — The first applications of radio waves for determining the distance of a reflecting surface were devoted to demonstrating the existence of the Heaviside layer as a portion of the upper atmosphere, now known as the ionosphere, which is responsible for the transmission of waves around the earth. After many years of speculation with a variety of indirect experimental evidence, the first direct demonstration of the existence of the ionosphere as a reflecting region was provided by Dr. (now Sir Edward) Appleton and M. A. F. Barnett towards the end of 1924 and during 1925.<sup>2</sup>

With the co-operation of the British Broadcasting Corporation the wavelength of the Bournemouth broadcasting station was varied over the range 385 to 395

By **R. L. SMITH-ROSE,**

D.Sc., Ph.D., M.I.E.E., F.I.R.E.

(National Physical Laboratory)

metres over a period of from 10 to 30 seconds, and the strength of the resulting signals at Oxford, about 100 miles distant, was measured. It was found that as the wavelength was varied, the received signal passed through a series of interference maxima and minima, indicating that the signal was the result of two sets of waves arriving by different paths; one set of waves was transmitted along the ground, while the other arrived by an indirect path after reflection from a layer. After verifying that the paths were in the same vertical plane, a measurement of the number of interference fringes caused by a known change in wavelength gave a measure of the height of the reflecting layer in the region, which later became known as the ionosphere.

This was the first classical

example of the use of frequency-modulated radio waves for determining the existence and location of a reflecting layer which had hitherto remained undetected by any direct experiment. We may therefore say that the Heaviside layer was the first object to be detected by radiolocation experiments conducted by British scientists working under our own Radio Research Board, and assisted by the British Broadcasting Corporation.

Shortly after the first of the above measurements were made, G. Breit and M. A. Tuve<sup>3</sup> began some tests in the United States of America, using interrupted continuous waves which were the equivalent of pulses of continuous waves about 1 millisecond in duration and with a recurrence frequency of 500 per second. At the receiving station a high-speed oscillograph was used to record the incoming signals and permit the examination of their waveform. In July, 1925, experiments

<sup>2</sup> *Nature*, 1925, Vol. 116, p. 857.

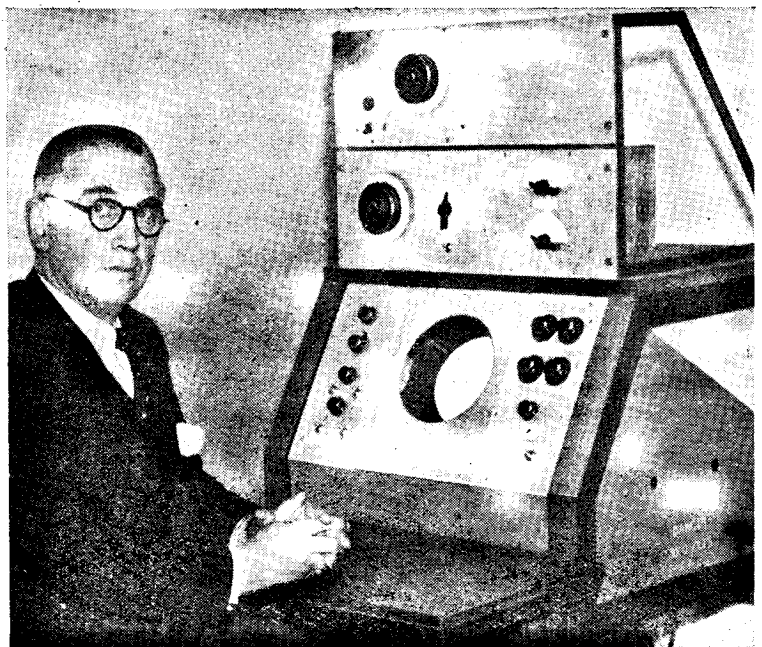

Sir Edward Appleton, discoverer of the Appleton Layer and a pioneer of radiolocation.

<sup>3</sup> *Proc. Roy. Soc. A*, 1925, Vol. 109, p. 621.

were made over a distance of 7 miles using wavelengths of 71 and 42 metres, and it was observed that the received pulses, nominally of square wave-form, were distorted by the attachment of humps, sometimes in duplicate. These humps clearly indicated the arrival of a second wave-train, or echo, by an indirect path; and from a measurement of its time retardation in relation to the original hump due to the direct or ground wave, the path differ-

mentioned above, a considerable amount of research work was devoted to the development and use of methods of determining the height of the reflecting layers of the ionosphere, using both the frequency-change and pulse-modulation methods. A direct comparison of the two methods showed that they gave substantially the same result in height determination; and in a paper published in 1931, E. V. Appleton and G. Builder<sup>5</sup> described cer-

waves to the E region of the ionosphere and back again is of the order of 0.002 second, it is clear that using pulses of the type just described, first the ground-wave pulse will be all over before the arrival of the first echo, and secondly, that there is ample interval between successive ground-wave pulses to receive and record one or more echoes. For visually observing, and subsequently photographing, the nature of the received signals, a cathode-ray oscillograph was used, with a time-base provided from a similar basic circuit using a squegging oscillator, the stroke-frequency of the time-base being synchronised with the pulse recurrence frequency of the sender, so that a stationary image on the oscillograph screen was produced showing the ground wave and any echo waves received.

The type of result obtained is shown in Fig. 8 (a), (b) and (c) which are reproduced from the paper referred to above, and are specimens of the actual records obtained by Appleton and Builder in 1931. Fig. 8 (a) shows the ground-wave pulses received without echoes, while Fig. 8 (b) shows the presence of a single echo signal after reflection from the F<sub>1</sub> layer. In this case the time interval can be measured in terms of the trace of an alternating current



"This important and by no means easy step (application of the principle of using radio waves reflected from aircraft for detection and location) was accomplished by a small group of British scientists working under the direction of Mr. (now Sir Robert) Watson Watt."

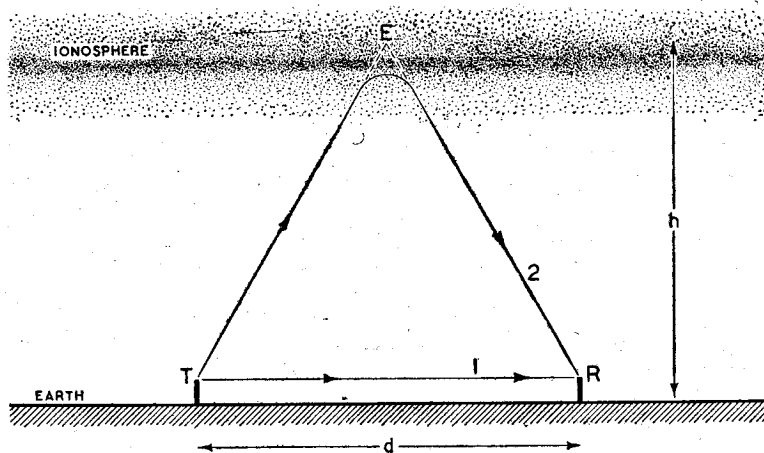

Fig. 7. Principle of technique used in determining height of reflecting regions in the ionosphere. Two sets of waves, 1 and 2, reach the receiver R from the transmitter T, along TR and TER respectively. From the difference in time of arrival, the path difference of these sets of waves, and so the height of the region E, can be determined.

ence of the two sets of waves could be determined. (See Fig. 7.)

In one of their publications, Breit and Tuve remark that their experiments on the above lines arose out of some work being carried out at the time on another method proposed by W. E. G. Swann and J. G. Frayne. It is also of interest to remark here that a United States patent was issued to H. Löwy<sup>4</sup> on an application filed in July, 1923, for a radio-frequency counterpart of Fizeau's method of determining the distance of a reflector, to which reference has already been made. In this patent Löwy describes an electronic switch used for alternately keying a transmitter and receiver, so that the latter is only in a sensitive condition after the pulse or train of waves has been emitted by the transmitter. It is not known whether this device was put to any practical use.

#### Later Ionosphere Researches.—

In the years following the dates

<sup>4</sup> U.S. Patent, 1,585,591—July, 1923.

tain important improvements in sending and recording technique which demonstrated the advantages and illustrated the possibilities of the pulse method, in so far as the signals arriving at the receiver due to the ground wave and successive reflected echoes could be separately received and recorded. At the sending station a valve oscillator arrangement was used in the well-known "squegging" condition to produce trains of oscillations or pulses of a duration of about 100 microseconds, spaced in time 0.02 second apart; i.e., at a recurrence frequency of 50 per second. This type of oscillator had been used previously to give a linear time base for cathode-ray oscillographic delineation of wave-form by E. V. Appleton, R. A. Watson Watt, and J. F. Herd,<sup>6</sup> and its application to ionospheric recording had been suggested by Appleton in 1928.<sup>7</sup>

Since the time of transit of the

<sup>5</sup> *Proc. Phys. Soc.*, 1932, Vol. 44, p. 76.

<sup>6</sup> *Proc. Roy. Soc. A.*, 1928, Vol. 111, p. 872.

<sup>7</sup> *Proc. Phys. Soc.*, 1928, Vol. 41, p. 49.

**Radiolocation—**

of frequency 1115 cycles per second shown below the signal record. Fig. 8 (c) is a snap photograph of the echo pattern on the cathode-ray tube, showing the ground wave G and the F region echo delineated on a time-base,

**Fig. 8.** (a) Record showing ground pulses only, and timing oscillation of frequency 1110 c/s. (b) Record showing ground pulses and echo received from F region about 3 milliseconds later. (c) Actual photograph of the ground wave and echo pattern as observed on the cathode-ray oscillograph screen. These records are reproduced from a paper by E. V. Appleton and G. Builder published in *Proc. Phys. Soc.*, 1932, Vol. 44. p. 82.

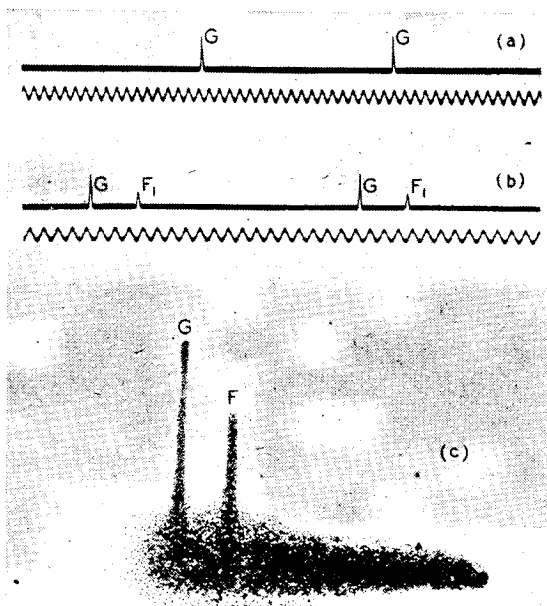

which in this case corresponds to a period of about 12 milliseconds. This was probably the first published picture of what is seen on the screen of the cathode-ray tube of a sending and receiving system used for determining range by measuring the time delay of the echo signal relative to that of the ground or direct path signal. The pulse-generating oscillator, and the cathode-ray tube and linear time-base combination so described by Appleton and Builder in 1931, formed the basis of the technique used some four years later in the first Radar experiments on aircraft detection conducted in this country.

**Aircraft Altitude Indicators.—**

While scientific research on methods of exploring the ionosphere was being conducted on the lines described above, a corresponding technique was being developed concurrently and on very similar lines for the purpose of producing an instrument for indicating the height of an aircraft in flight above the ground. For

example, in 1928 J. O. Bentley<sup>8</sup> described a method in which frequency-modulated waves are radiated towards the earth from a transmitter on the aircraft. A receiver, also on the aircraft, receives the waves after reflection from the ground and combines

them with those received direct from the transmitter, the latter waves differing slightly in frequency due to the time of travel of the waves to the ground and back again. The frequency of the beats in the receiver resulting from the two sets of waves is thus a measure of the height of the aircraft above the ground beneath, as distinct from its altitude above sea-level, which is what is indicated by the type of altimeter dependent upon barometric pressure. This instrumental technique was later improved by L. Espenschied<sup>9</sup> in 1930, and culminated in a commercial pattern of "terrain clearance indicator" produced by the Bell Telephone Laboratories in 1938. The apparent delay in the successful production of this instrument was due to the fact that the heights in question are much smaller than those involved in ionospheric research, and that therefore the echo-time intervals to be measured are correspondingly less; e.g., 10 microseconds for about

5,000ft. An illustrated description of this method of echo sounding for aircraft was given in *Wireless World* for February 2nd, 1939.

The pulse modulation method of altitude determination in aircraft is clearly applicable, provided that the pulse lengths are reduced sufficiently to discriminate the echoes arriving at a much shorter time delay than is the case of the ionospheric work. Such a system was, in fact, described by the Submarine Signal Company in June, 1933.<sup>10</sup> Here the scheme proposed for measuring distances used pulses of electric waves, in association with a means of receiving the reflected echoes, and determining the time interval between the emitted and received pulses with the aid of a cathode-ray tube and synchronized time-base.

**The Origin of True Radar.—**

The above section described the use of methods of measuring the time delay in transit of reflected radio waves for determining the distance of large surfaces, such as the ground or ionosphere. In contemplating the possibilities of determining the distance of smaller objects such as ships or aircraft, consideration must be given to the reflecting properties of bodies which are not large and may even be smaller than the length of the waves used. With light waves, this question does not arise except in the case of detecting objects of microscopic dimensions, the length of the waves being of the order of a few hundred-thousandths of a centimetre; but with radio waves the dimensions of the object from which reflection is desired may be comparable and even smaller than the wavelength used. Although the classical laws of reflection enunciated by Fresnel and verified experimentally in the case of optical phenomena, were equally applicable to the longer electric waves in the radio-frequency portion of the spectrum, there was still lacking at the beginning of the 1930 decade a satisfactory practical demonstration that the reflection or scattering of radio waves from an object such as a ship or aircraft was of a sufficiently high order to be detectable.

For this reason, it is interesting and important to record that in December, 1931, the British Post

<sup>8</sup> U.S. Patent 2,011,392—August, 1928.

<sup>9</sup> U.S. Patent 2,045,071—April, 1930.

<sup>10</sup> British Patent 406,903—June, 1933.



Office<sup>11</sup> observed the effects of reflection of waves from aircraft in the course of some radio communication tests being conducted on a wavelength of 5 metres over a path 12 miles long. Extracts from the station log show that on various occasions the received signal was subject to a beat type of variation, which was not only audible but was detectable on the volume indicator of the receiver. The amplitude of the beat varied from about  $\pm \frac{1}{2}$  db. up to 10 db. on some occasions, and at all times when this occurred an aircraft was found to be flying in the neighbourhood at various distances up to  $2\frac{1}{2}$  miles and at heights up to 500ft. The period of the beats varied from 5 to 15 per second; and this is to be compared with the calculated value of 11 per second for an aircraft flying directly towards the receiving aerial at a speed of 60 m.p.h.

This experience was confirmed by further observations made in America in 1932 by engineers of the Bell Telephone Laboratories in the course of an investigation of the mode of propagation of radio waves in the range of wavelengths between 4.7 and 5.7 metres. In a paper<sup>12</sup> describing this work by Messrs. C. R. Englund, A. B. Crawford and W. W. Mumford, and published in March, 1933, it is stated that an aircraft flying about 1,500ft. overhead and approximately along the line joining transmitter and receiver, a noticeable flutter of about four cycles per second was produced in the low-frequency detector meter of the receiver. When observations were carried out in the neighbourhood of an airport, it was noticed that near-by aircraft produced field strength variations up to 2 db. in amplitude. Similar re-radiation was noticed at various subsequent times, occasionally when the aircraft was invisible.

It was thus clearly established, over ten years ago, that radio waves reflected from aircraft in flight could be detected with suitable receiving equipment on the ground; and it now remained to be seen whether this principle could be applied to the development of a technique for the detection and location of aircraft at ranges and under conditions of

practical utility as an aid to navigation in peacetime and as a defensive weapon in war. This important, and by no means easy, step was accomplished by a small group of British scientists working under the direction of Mr. (now Sir Robert) Watson Watt, who was at the time Superintendent of the Radio Department of the National Physical Laboratory, incorporating the Radio Research Station at Slough where the initial experiments in the radio location of artificial objects in this country were conducted.

Under the auspices of the Radio Research Board, the Research Station had been responsible for a wide variety of investigation work on the propagation of waves, the study of atmospherics and of direction-finding, and Watson Watt and his colleagues brought all the resources of this work and the resulting technique to bear on the problem of making the radiolocation of artificial objects a practical and worthwhile proposition. In association with Appleton, he had been responsible for much of the application of the cathode-ray tube as a research tool for delineating the wave-form of atmospherics; Watson Watt, in association with the late J. F. Herd,<sup>13</sup> had also devised the original form of visual direction finder, using twin balanced amplifiers and a cathode-ray indicator.

The staff which had developed these techniques, supplemented by those who had converted Appleton's technique for ionospheric exploration into a routine recording equipment, were in a unique position to demonstrate the possibilities of aircraft detection and location by radio methods. Prominent among the members of the staff of the Radio Research Station who were responsible for the technical requirements of this early work were L. H. Bainbridge Bell who undertook a great deal of apparatus design and development at Slough and Drs. E. G. Bowen and A. F. Wilkins, who worked very successfully on the special problems associated with the transmitting and receiving equipment respectively.

After some preliminary experiments, these and other members of the staff under Watson Watt's

supervision established a new "ionospheric" exploring station on the East Coast of England, at which were installed the, for those days, high-power pulse transmitters made at Slough, together with suitable receivers and appropriate aerial systems and goniometers for determining the direction of arrival of the echo waves, both in azimuth and elevation, scattered back to the receiver from the aircraft which was illuminated, as it were, by the flood-lighting effect of the radiation from the transmitter.

Thus it was that in the early days of 1935-36, the technique of radiolocation of artificial objects was born in this country, and the members of that small band of scientists and technical assistants will well remember the thrill of seeing for the first time a clear image on the cathode-ray tube due to an aircraft which was so far away as to be invisible to the naked eye; the distance of the pip along the base line gave the range of the aircraft while its bearing and elevation were obtainable by turning the knobs of the goniometers.

Much hard work and not a little ingenuity were still required to convert the technique from an experiment in the hands of scientists to a working system which could be used and maintained by this miscellaneous type of personnel which was at that time provided by the Service departments for this new "side-line" of radio communication or signalling. It was not long, however, and well before war was declared, before more than one Service station was in operation, and the plotting of the tracks of various aircraft, some on their legitimate civil or military duties, and others whose business was perhaps less innocent, was a matter of daily routine.

#### The Radio Research Board.—

The foregoing paragraphs have explained in a skeleton manner how radiolocation came about in this country, as a practical application of the combined techniques devised originally for the scientific exploration of the ionosphere and for direction-finding. All these investigations were in progress for nearly twenty years before the present war under the auspices of the Radio Research

<sup>11</sup> Radio Report No. 223, 3rd June, 1932, Part V.

<sup>12</sup> Proc. I.R.E., 1933, Vol. 21, p. 475.

<sup>13</sup> Journal I.E.E., 1926 (Proc. Wireless Section, Vol. 1, p. 89).

**Radiolocation—**

Board, and the story here told provides an outstanding example of the manner in which a carefully planned programme of research on a broad national basis will in the long run yield results of immeasurable value. It will thus be appreciated that Radar came about in this country as a synthesis of knowledge and experience obtained in the course of scientific investigations and effectively applied to a practical issue, rather than as an invention by any one or more individuals to meet a specific demand.

This aspect of the whole subject was emphasised in the course of a speech made in July, 1943, on "Radio Research and Production Before, During and After the War." G. M. Garro-Jones, Parliamentary Secretary to the Ministry of Production, paid the following tribute to those responsible for this pioneer work in modern radio research.<sup>14</sup>

"In the decade 1925-35 the State contribution came through the Radio Research Board of the Department of Scientific and Industrial Research, in full activity on a programme of work which largely centred on the effects of atmospheric processes on radio. The Board and the National Physical Laboratory also did great things in an active programme of measurement and standards work.

Radiolocation, by far the most important national asset ever to emerge from the National Physical Laboratory, was a natural but not inevitable synthesis of techniques developed within the Radio Research Board's programme. It revived the laboratories of the defence services. . . . There is little need to emphasise the tremendous value of radio devices in the present war and the great part that the radio industry is playing in prosecuting the war to a successful conclusion. Radiolocation devices, radio navigational aids, and radio communication equipments have proved of unforgettable value when our very survival was in jeopardy, and are now proving of ever-growing value in offensive operations."

Having thus presented a review of the manner in which radar originated in this country, this article will conclude with a brief review of what appeared to be in

progress abroad during the same period.

**Work in Other Countries.**—An indication of the trend of thought and activities in other countries in the years before the outbreak of the present war can be gained from a perusal of one or two publications which are available. Reference has already been made to the patent taken out in U.S.A. by H. Löwy; but the main development in America seems to have taken place partly in the Service research institutions, and partly at the Bell Telephone Laboratories. The latter organisation, after developing the aircraft altimeter, demonstrated the use of this instrument in a modified form to the detection of ships over short distances.<sup>15</sup> With regard to the Continent, it is to be noted that the Telefunken Company filed a patent in 1935, disclosing an arrangement similar to the frequency-change method used by Appleton, with the modification also suggested by Appleton<sup>16</sup> that, while the carrier frequency remained unaltered, the frequency of the modulation was varied, while the number of interference fringes was counted at the receiver. The American journal *Electronics* published in September, 1935, a two-page set of illustrations descriptive of the aircraft detection arrangements alleged to be under development by the Telefunken Company. An interesting feature of this pictorial display was the reference to the use of wavelengths in the band 5 to 15 cm. and of magnetron valves with permanent magnets developed specially for wavelengths of about 10 cm. An alternative scheme was also described by the Telefunken Company in 1937,<sup>17</sup> which utilised two beams of transmitted waves to produce a stationary interference pattern, the disturbance of which by an object moving across it was detected at the receiver.

In Italy, E. Montu described a twin rotating aerial arrangement for locating aircraft in bearing and elevation, and the patent specification of this arrangement was published in this country in December, 1936.<sup>18</sup> About three years later U. Tiberio published the first part of a comprehensive paper,

discussing various aspects of the radiolocation of ships and aircraft, in the Italian periodical *Alta Frequenza*<sup>19</sup>: the later parts of the paper were apparently withheld from publication after the outbreak of war. An interesting development in France was the fitting of the steamship *Normandie* with an iceberg detector, which was described and illustrated in *Wireless World* for June 26, 1936. This equipment comprised a transmitter and receiver operating on a wavelength of 16 cm. and mounted in the fore part of the ship. The transmitting and receiving aerials were of the dipole type and mounted in parabolic reflectors, 75 cm. in diameter and installed at a distance of 6 metres apart; this arrangement provided a beam having a width of  $\pm 10$  deg. at half amplitude, and the reflectors could be rotated automatically through an arc of 40 deg. When the receiver indicated the arrival of a signal from the transmitter after reflection from a distant object, the two parts of the equipment could be manually and accurately trained on this object, the distance of which could then be calculated from the directions of the transmitted and arriving waves. In this manner it was claimed that a coastline could be located at a distance of 20 km., and large ships at ranges up to about 7 km.

Such was the state of affairs abroad as judged by the sparse published information available. As to what was the actual state of affairs at the outbreak of the war in Europe must remain a matter of speculation at the present time; but many readers will look forward with interest to the time when more facts may be disclosed, and the progress of the Radar technique and operation conducted by the various belligerent nations may be described and compared.

<sup>19</sup> *Alta Frequenza*, 1939, Vol. 8, p. 305.

**OUR COVER**

THIS month's illustration deals with one of the earliest practical devices for locating objects at a distance by means of reflected wireless waves. The photograph shows the transmitting and receiving reflectors of the "obstacle detector" installed by the Société Française Radio-Electrique aboard the liner *Normandie*.

<sup>15</sup> *Bell Laboratories Record*, June, 1943.

<sup>16</sup> *Proc. Phys. Soc.*, 1930, Vol. 42, p. 323.

<sup>17</sup> French Patent 809,612—August, 1936.

<sup>18</sup> British Patent 478,456—January, 1936.

<sup>14</sup> *Engineering*, Aug. 13, 1943, p. 135.



# A New Versatile

# tone CONTROL CIRCUIT

## I.—Basic Principles of Tone Control

A LARGE number of tone control circuits have been published over the period of the last ten years (see references), all possessing some advantages and disadvantages. Many circuits are commonly used which, when turned to the maximum bass position just reduce the "top," their only redeeming feature being their simplicity and cheapness.

One requirement of any good tone control circuit is the ability to *increase* the treble or bass relative to the middle frequencies. In other words, if the bass tone control is turned in the "increase bass" direction, the amplitude of the lower frequencies will be increased relative to what they were originally, the middle and high frequencies remaining the same. A practical tone control circuit which achieves this object will be described in the second part of this article.

One point that is not always realised is that it is impossible to obtain an increase or boost of any frequency if the maximum gain of the amplifier is already being utilised. This means that in order to obtain an increase in the amplitude of the low or high frequencies it is necessary that the normal amplification should be less than the maximum by the amount of increase required.

By G. N. PATCHETT,

B.Sc., Grad.I.E.E., A.M.Inst.E.,  
Assoc. Brit.I.R.E.

This usually means that at least one extra valve is required for tone control.

Another point which is worth mentioning is that if bass or treble boost is used the output stage must be capable of handling

the type of circuit consisting of a frequency discriminating filter or potential divider circuit, as this is by far the most versatile and successful so far employed. Fig. 1

shows the connection in an amplifier of a frequency discriminating filter, consisting of two impedances  $Z_1$  and  $Z_2$ , the impedance is at least one being dependent on frequency.  $R_1$  is the anode resistance of the valve  $V_1$ ,  $C_1$  is the DC blocking condenser and  $R_2$  the grid resistance of the valve  $V_2$ . The load on the valve  $V_1$  is not only the resistance  $R_1$ , but, neglecting the effect of the resistance  $R_2$  and the condenser  $C_1$ , the combined impedance of the resistance  $R_1$  and the impedance of the tone control filter  $Z_1 + Z_2$ , in parallel. In order to keep the distortion to a minimum the impedance of  $Z_1 + Z_2$  should be as high as possible. A limit to the impedance  $Z_2$  is fixed by the fact, that, in order to avoid alteration in the characteristic of the tone control filter, the value of the resistance  $R_2$  must be considerably greater than the impedance  $Z_2$ , a limit to the value of  $R_2$  being determined by the maximum grid-cathode resistance allowable for the valve  $V_2$ . Since the impedance of the tone control filter  $Z_1 + Z_2$  is usually smaller than the normal grid resistance used

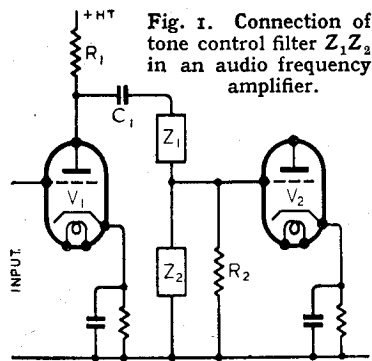

Fig. 1. Connection of tone control filter  $Z_1, Z_2$  in an audio frequency amplifier.

a much greater output than normal. For example, suppose that the normal output is one watt, then if the bass increase of only 3.2 times (10 db) is used the output stage will have to handle 10 watts at the low frequencies, since the power is proportional to the voltage squared.

We will begin by considering

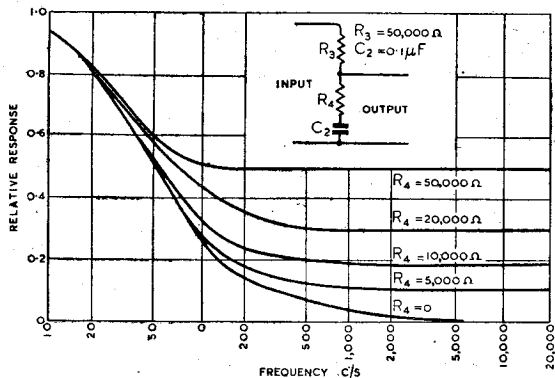

Fig. 2. Basic bass tone control filter showing the effect of varying the resistance  $R_4$ .

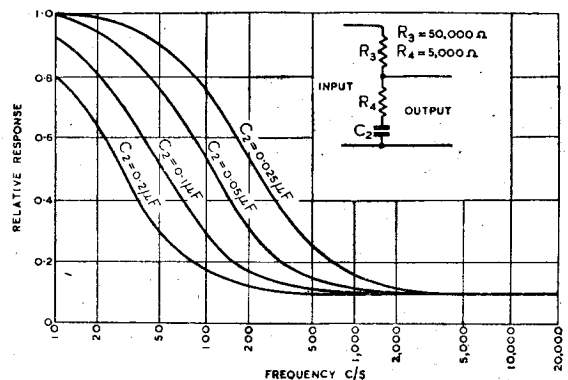

Fig. 3. Bass tone control filter showing the effect of varying the capacity of the condenser  $C_2$ .

**Tone Control Circuit—**

in resistance capacity coupling, the value of the condenser  $C_1$  must be increased so that its reactance at the lowest frequency is small compared with the impedance of  $Z_1 + Z_2$ , otherwise it will cause alteration in the frequency characteristic of the filter.

the lower portion of the tone control filter, which, in turn, increases the output/input ratio. Eventually a frequency is reached where the reactance of the condenser  $C_2$  is high compared with the resistance  $R_3$ , making the output equal to the input.

Considering the filter circuit alone, the maximum "gain" is unity (output = input). If therefore, a maximum increase of the

of increase at the low frequencies is now required. (Note, variation of  $R_4$  is not practical since this would cause a large change in volume.)

This may be achieved in one of three ways:—

(a) By variation of the capacity of the condenser  $C_2$ . The result of this is shown by the curves of Fig. 3. The arrangement has two disadvantages: first, the change can only be made in steps since the capacity of the condenser  $C_2$  cannot be reduced sufficiently to make it continuously variable, and, second, variation of the value of the condenser does not directly control the magnitude of the increase in the bass, but rather, the frequency at which the increase starts.

(b) By the use of a variable resistance  $R_5$  across the condenser  $C_2$ , as shown in the diagram of Fig. 4. The effect of the resistance across the condenser is to prevent the impedance of the lower portion of the network from increasing beyond that of the resistance  $R_5 + R_4$ . This method gives the continuous variation of the amount the low

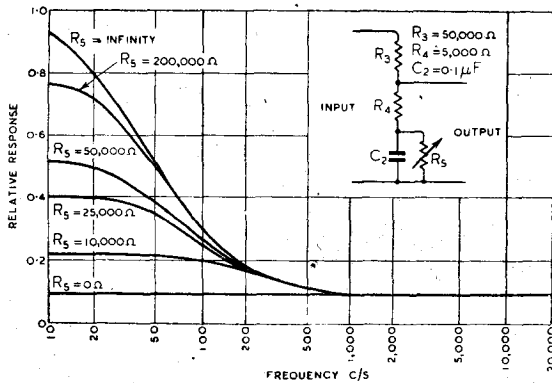

Fig. 4. Effect of varying the value of the resistance  $R_5$ .

**Bass Tone Control.**—A basic circuit for increasing the response in the base is shown in Fig. 2. At the middle frequencies where the reactance of the condenser  $C_2$  is small compared with the

bass of 10 times (20db) is required, the output at the middle frequencies must be reduced to 1/10 of the input, i.e.

$$\frac{R_4}{R_3 + R_4} = \frac{1}{10}$$

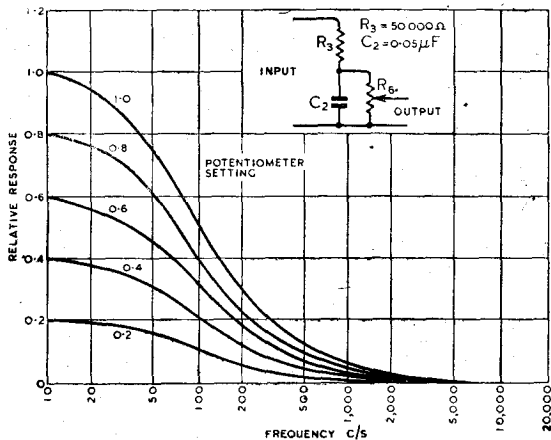

Fig. 5. Modified tone control filter, showing the effect of varying the setting of the potentiometer  $R_6$ .

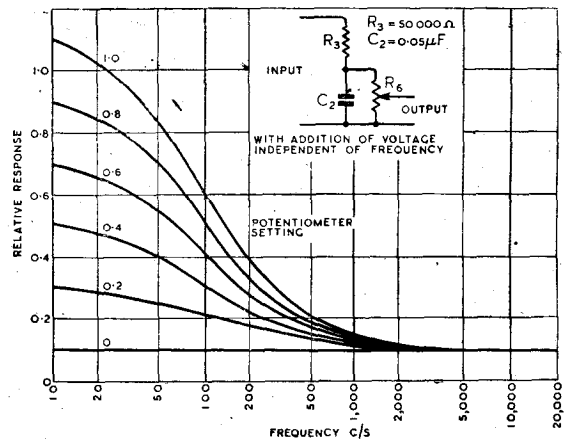

Fig. 6. Tone control filter as in Fig. 5 with the addition of a voltage independent of frequency and of amplitude equal to 1/10th of the maximum output of the filter.

resistance  $R_4$ , the ratio of the output voltage to the input voltage, is determined by the resistances  $R_3$  and  $R_4$  and given by the formula  $\frac{R_4}{R_3 + R_4}$ . As the frequency is decreased, the reactance of the condenser  $C_2$  increases, so increasing the impedance of

A suitable value for the resistance  $R_3$  is 50,000 ohms, making the resistance  $R_4 = 5,500$  ohms. Since great accuracy is not required, it is convenient to make the latter 5,000 ohms. The effect of varying the value of the resistance  $R_4$  is shown by the curves of Fig. 2. A method of varying the amount

frequencies are increased but has the disadvantage of altering the shape of the frequency-output characteristic of the filter, as seen by the curves of Fig. 4, calculated for various values of the resistance  $R_5$ , i.e. at the lower settings of the control, the magnitude of the increase is constant over a con-

siderable frequency range, rather than the more desirable increase in output as the frequency decreases.

method of obtaining the voltage independent of frequency and adding it to the output from  $R_6$  will be described later.

treble tone control by replacing the condenser  $C_2$  by an inductance. The effect of changing the inductance and the resistances

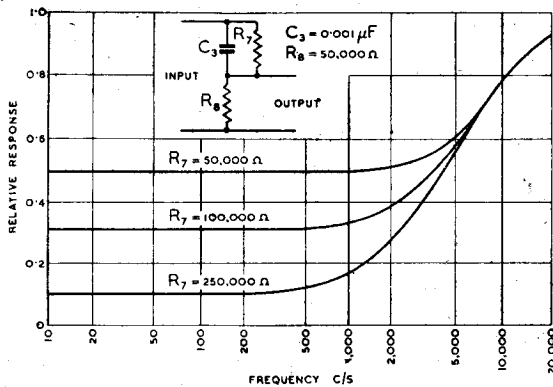

Fig. 7. Basic treble tone control filter showing the effect of varying the resistance  $R_7$ .

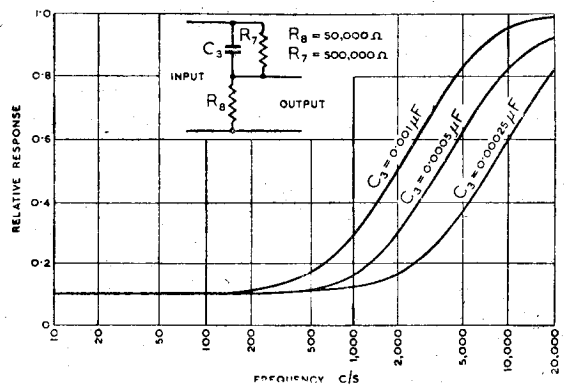

Fig. 8. Treble tone control filter showing the effect of varying the condenser  $C_3$ .

(c) A method devised by the author where the same shape of curve is produced at all settings of a continuously variable tone control. By omitting the resistance  $R_4$  and placing a high resistance "volume control"  $R_6$  across the condenser  $C_2$  as shown in the circuit of Fig. 5, the characteristics as shown in the same figure are obtained. If the output from the resistance  $R_6$  is added to a voltage independent of frequency, the characteristics as shown in Fig. 6 will be the result. The tone control  $R_6$  now gives a continuous variation in the magnitude of the increase at the low frequencies while having no effect on the shape of the curves. The

**Treble Tone Control.**—A similar circuit to that for the bass tone control may be used for

$R_3$  and  $R_4$  on the increase in the output at the high frequencies would be similar to the effect on the increase in the output of the low frequencies obtained by changing the condenser  $C_2$  and the resistances  $R_3$  and  $R_4$  of the

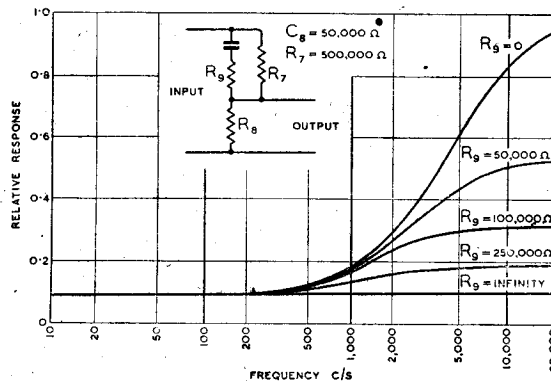

Fig. 9. Effect of varying the resistance  $R_9$  on the treble tone control filter.

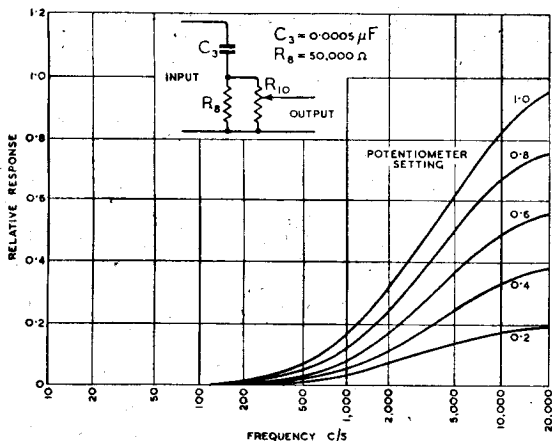

Fig. 10. Modified treble tone control filter showing the effect of varying the setting of the potentiometer  $R_{10}$ .

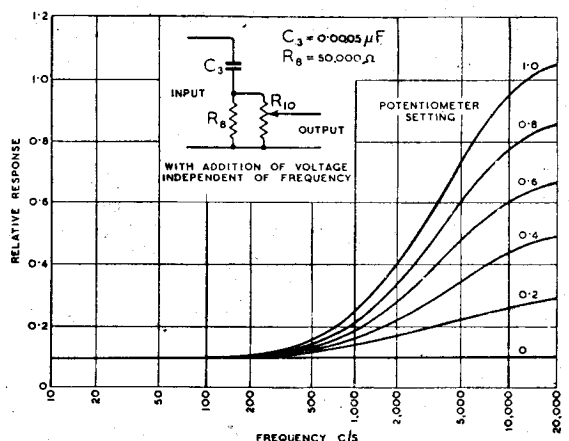

Fig. 11. Treble tone control filter of Fig. 10 with a constant voltage equal to 1/10th the maximum output of the filter.



**Tone Control Circuit—**

bass tone control just described. The use of an inductance has two disadvantages: an inductance of known value is not so easily obtained as a condenser or a resistance and there is always a tendency for the inductance to pick up hum. To avoid these difficulties a circuit using resistances and condensers only is used.

The basic circuit is shown in the diagram of Fig. 7. At middle frequencies, where the reactance of the condenser  $C_3$  is high compared with the resistance  $R_7$ , the two resistances  $R_7$  and  $R_8$  act as a potential divider, the ratio

of output to input being  $\frac{R_8}{R_7 + R_8}$ .

Using a suitable value of 50,000 ohms for the resistance  $R_8$ , the effect of  $R_7$  is to determine the output at the middle frequencies and the result of varying  $R_7$  is shown by the curves of Fig. 7. The variation of  $R_7$  has a very similar, but opposite, effect to the variation of the resistance  $R_4$  of the bass tone control filter shown by the circuit of Fig. 2. Variation in the magnitude of the increase of the high frequencies may be obtained by one of three methods similar to those used in bass tone control.

(a) By the variation of the capacity of the condenser  $C_3$ . The effect of varying the capacity of the condenser  $C_3$  is shown by the curves of Fig. 8, where it will be noted that a direct control of the amount of treble increase is not obtained, but rather, the frequency at which the increase starts. A continuous variation can be obtained by using a  $0.0005\mu\text{F}$  two gang condenser for  $C_3$ , connecting the two sections in parallel to make a total of  $0.001\mu\text{F}$ , although this is rather clumsy.

(b) By the use of a variable resistance in series with the condenser  $C_3$ . If a variable resistance  $R_9$  is placed in series with the condenser  $C_3$  as shown by the diagram of Fig. 9. The impedance of the top portion of the network is prevented from becoming appreciably less than the value of the resistance  $R_9$ , i.e. the magnitude of the increase of the high frequencies is limited as seen by the curves of Fig. 9, calculated for different values of  $R_9$ . The effect of varying the

resistance  $R_9$  is similar, but opposite, to that of varying the resistance  $R_5$  of the bass tone control circuit shown in Fig. 4, and the method has the same disadvantage, i.e. alteration of the shape of the curves.

(c) A method similar to that described for the bass tone control circuit where a continuous control is obtained without altering the shape of the curves. By placing a "volume control"  $R_{10}$  across the resistance  $R_8$  (or making  $R_8$  the volume control) and removing  $R_7$ , as shown in the diagram of Fig. 10, the curves as shown in the same figure are obtained, for various settings of the control  $R_{10}$ . By adding the output from  $R_{10}$  to a voltage independent of frequency the results as shown in Fig. 11 are obtained.

**PARALLEL "R" AND SERIES "C" ON THE SLIDE RULE**

USERS of the ordinary 4-scale type of slide rule (i.e., without the reciprocal scale) will no doubt be interested in the following facts which are not generally known:—

To find the reciprocal of any number, all that is necessary is to reverse the slider and close up rule fully. Reciprocals of numbers appearing on scale "A" may now be read directly opposite on scale "B" (now upside down). By leaving slider in this position, it is now possible to calculate any combination of resistors in parallel—or condensers in series—without further movement of slider: the cursor only is required.

For, say, three resistors in parallel, proceed as follows: Set cursor to value of  $R_1$  on scale "A" and note corresponding number on scale "B." Repeat for  $R_2$  and  $R_3$  and add total of numbers on scale "B." Reset cursor to this total on scale "B" and the absolute resistance value appears opposite in scale "A."

After a little practice this will be found to be a much quicker method of calculation than the old formula and it reduces the operation to one of simple addition. This system may of course be used with equal ease for calculating the total capacity of any number of condensers in series, and the procedure is the same.

H. E. S.

**REORGANISING BROADCASTING**

VARIOUS schemes for the more or less drastic reorganisation of the B.B.C., whose Charter expires next year, have already been put forward. The latest proposals in this direction appear in a booklet\* published by the Arts Advisory Committee of the Communist Party. These proposals are summarised as:

(1) Constitution changes to turn the B.B.C. from a Royal monopoly into a public service under full Parliamentary control and to ensure that its administration is no longer carried on in secrecy.

(2) A decentralised organisation, made up of a number of autonomous regional broadcasting units, basing their work on the needs and interests of people in their area, and a national organisation designed to fulfil a new and more positive cultural rôle in various fields.

(3) The opening up of new channels of communication between broadcasting and the public, through new forms of advisory organisation which will draw in the audiences, the amateurs and the professional workers in various fields to co-operate in the making of programmes.

(4) A change in the status of broadcasting workers, which will give them full freedom to participate in the political and cultural life of the community, to discuss their work publicly, to mix with their audiences and with workers in other fields, and, if they wish, work outside broadcasting.

(5) More money.

Arguments for advertising broadcasting are examined and this system of financing programmes is emphatically condemned as "a political danger and a social evil."

\* "The B.B.C." pp. 24, 9d. net. The Communist Party, 16, King Street, London, W.C. 2

**RE-STARTING TELEVISION**

SOME of the more spectacular contributions of radio to the war effort, revealed for the first time at the Radio Industry Council's recent formal inauguration, are enumerated on page 87. In addition, it was disclosed that the R.I.C. has submitted to the Hankey Committee a proposal for restarting British television on pre-war standards as soon as the German war ends. At the same time, work should start on a system for distributing television over the whole country by radio links. This was the method of distribution envisaged by the industry before the outbreak of war.

# CATHODE BIAS IN PUSH-PULL STAGES

## Is a By-pass Condenser Necessary?

By W. T. COCKING,  
A.M.I.E.E.

**D**OUBT is frequently expressed about the need for using a by-pass condenser across the cathode-bias resistance of a push-pull stage when this resistance is common to both valves. Text-books are usually silent on the subject and, in the rare cases when they do refer to it, are apt to conflict in their advice.

An exact analysis of the effect of omitting the condenser is quite easy to carry out if the valves are assumed to have completely linear characteristics. While such an analysis helps to an understanding of the action of the bias resistance, it is by no means sufficient. One of the chief characteristics of a push-pull amplifier is its ability to give an undistorted output when the valves are individually non-linear. It is, therefore, of the first importance not to restrict the investigation to the linear condition.

A complete analysis in the non-linear condition is impracticably complicated, however, but useful information can be obtained quite readily by investigating the circuit from two different points of view. An analysis based on the assumption of linear valves will reveal the effect of the cathode resistance on the balance of the stage when the two sides are somewhat dissimilar—as they usually are in practice. A further analysis, carried out for identity between the two sides, will show the effect of the cathode resistance on distortion when the valves are not linear.

From these two results a very good idea can be obtained of what happens when the valves are not only non-linear but the components on the two sides are not identical in value. It is true that this does not enable the exact performance to be calculated, but for the small degrees of distortion and the small amounts of unbalance that are normally permitted the approximation is sufficiently accurate for most purposes.

The effect of the cathode resistance on the balance of the stage will be considered first and it will be assumed that the two valves are each quite linear but not necessarily alike. A typical output stage is shown in Fig. 1, and the circuit is also identical with that of a transformer-coupled intermediate stage. In the latter case T would be an intervalve transformer and would have a centre-tapped secondary for feeding the next push-pull stage. The resistance  $R_L$  represents the output load circuit; in the case of an output stage it stands for the speaker impedance, whereas in an intermediate stage it represents the resistance shunting the secondary of the transformer.

Fig. 1. An equalising effect is obtained with  $R_c$  unshunted.

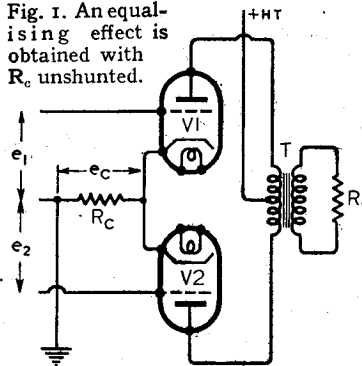

In a general way it is quite easy to see what happens. Suppose V1 and V2 are alike but that the input  $e_1$  to V1 is greater than the input  $e_2$  to V2. Clearly the alternating anode current of V1 will be greater than that of V2. The currents are in opposite phase through  $R_c$  and tend to cancel. As they are unequal, the effective current is their difference and this develops an alternating voltage across  $R_c$ . The anode current, however, depends on the grid-cathode voltage and this is equal

to the difference between the input and the cathode-earth voltages.

In the case quoted of  $e_1$  greater than  $e_2$  the cathode-earth voltage is in phase with  $e_1$  but in opposite phase to  $e_2$ . The grid-cathode voltage of V1 is, therefore,  $e_1$  minus  $e_c$ , while the grid-cathode voltage of V2 is  $e_2$  plus  $e_c$ . Thus the grid-cathode voltage of V1 is less than  $e_1$  and that of V2 is greater than  $e_2$ . The anode currents are proportional to the grid-cathode voltages, consequently the currents in V1 and V2 are less and greater respectively than they would be if no voltage were developed across  $R_c$ . In other words, when the input voltages are unbalanced the anode currents are not as much out of balance as they would be if  $R_c$  were shunted by a large-capacity condenser.

There is, in fact, feed-back from the bias resistance, and it is negative on the side with the greater input and positive on the side with the smaller input. It thus tends to equalise the currents. By a similar process of reasoning it can be shown that the action is the same if the inputs are equal, but V1 and V2 are unlike either in their AC resistances or their amplification factors.

When  $e_1$  and  $e_2$  are equal and an ideal output transformer is used, unbalance can be caused only by the valves. In practice, this is the predominant cause of unbalance with good quality components. It is then easy to show that the ratio of the alternating anode currents is given by equation (1) in the Appendix.

The order of magnitude of the self-balancing action can be seen by a typical example. Suppose that the two valves are triodes having amplification factors of 6, but that one has an AC resistance of 1,000 ohms while the other is only 800 ohms. The bias resistance can be taken as 500 ohms. It is not necessary to specify

$n^2 R_L$  in this case, because the amplification factors are the same.

On inserting values in equation (1) it will be found that the alternating anode current of the lower resistance valve is 2.5 per cent. greater than that of the other. The use of a sufficiently large by-pass condenser across  $R_c$  is equivalent to making  $R_c$  equal to zero, and the higher current then becomes 25 per cent. greater than the other. Inasmuch as the omission of a by-pass condenser reduces the unbalance from 25 per cent. to 2.5 per cent., it is clear that the self-balancing action is of considerable magnitude.

With resistance, instead of transformer, coupling the results are similar, but they are not quite the same, for the anode circuits are not coupled together. The coupling in the transformer precludes any possibility of inequality between the two alternating anode voltages—only the currents can be different. With resistance coupling, however, there is no such coupling and both currents and voltages can be different.

### R-C Coupling

The basic circuit of a resistance-coupled stage is shown in Fig. 2. The symbol  $R_1$ , although shown against the coupling resistance of  $V_1$ , is actually used to denote the value of this resistance in parallel with the grid leak of the next stage.  $R_2$  similarly denotes the AC load impedance of  $V_2$ .

By exactly the same reasoning as before, it can be shown that any inequality of the anode currents caused by inequality of the inputs or valves is reduced by the feed-back action from  $R_c$ . As the output voltages are equal to the products of the respective anode currents and load resistances, the self-balancing action occurs on the voltages as much as on the currents.

This is, however, true only if  $R_1$  and  $R_2$  are identical. If they are not, the effect of  $R_c$  may be to do more harm than good.  $R_c$  always tends to equalise the currents, but if  $R_1$  and  $R_2$  are unequal, balanced currents will not give balanced output voltages.

That this is indeed the case can be seen by supposing that the input voltages and valves are identical, but that  $R_1$  is less than  $R_2$ . Then the current through

$V_1$  will be greater than that through  $V_2$ , but in the absence of feed-back from  $R_c$  the output voltage developed by the higher current across the lower resistance  $R_1$  will be less than that developed by the lower current across the higher resistance  $R_2$ .

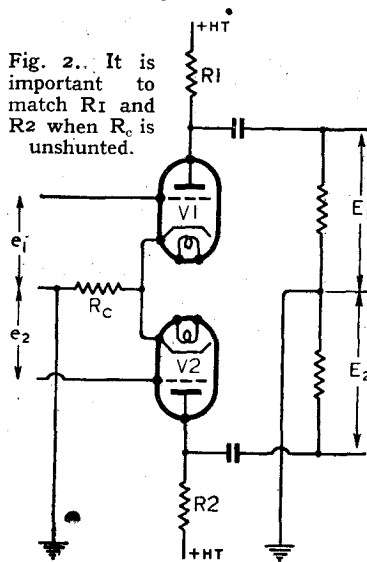

This is because the currents are dependent not only on  $R_1$  and  $R_2$ , but also on the valve resistances, so that the ratio of the currents is smaller than  $R_2/R_1$ .

When  $R_c$  plays its part, the feed-back reduces the current in  $V_1$  and increases it in  $V_2$ , so tending to equalise the currents. The decrease of current in  $V_1$ , however, still further reduces the voltage across  $R_1$ , and the increase of current in  $V_2$  further increases the voltage across  $R_2$ . The effect of  $R_c$  in this case, therefore, is to increase the voltage unbalance.

As compared with the condition when  $R_c$  is shunted by a large capacity, the feed-back effect reduces unbalance in the output voltages when they are caused by a lack of identity in either the input voltages or the valves. It increases the unbalance, however, when it is caused by inequality of the load resistances. When all elements are unbalanced the feed-back may either increase or decrease the unbalance—depending on the precise relations involved.

Equation (2) enables the performance to be readily calculated. As an example assume that the input voltages and amplification factors are equal. Let the amplification factors be 40,  $R_1 = R_2 =$

50,000 ohms,  $R_c = 1,000$  ohms,  $R_{a1} = 20,000$  ohms, and  $R_{a2} = 15,000$  ohms. Then when  $R_c$  is by-passed the unbalance becomes 7.5 per cent., but when there is no shunt condenser it is only 3 per cent. On the other hand, using the same values but making  $R_2 = 40,000$  ohms, with the valve resistances equal at 15,000 ohms, the unbalance is 17 per cent. with feed-back from  $R_c$  and 15 per cent. without feed-back.

It is clear, therefore, that from the point of view of balance it is definitely advantageous to omit the by-pass condenser from  $R_c$ , but that it then becomes somewhat more important to employ matched coupling resistances. When  $R_c$  is not by-passed, the equality of the coupling resistances is much more important than the matching of the valves or the balance of the input voltages. As ordinary resistors have a tolerance of  $\pm 20$  per cent., the possible unbalance between resistors nominally alike is as much as 40 per cent. For good balance nothing worse than 2 per cent. tolerance resistors should be used, but it is not necessary that they should be within 2 per cent. of their nominal value, merely that they should be alike within this tolerance.

It is now necessary to consider the effects of non-linearity in the valves. To simplify things as much as possible, it will be assumed that the input voltages are equal and that the valves and their individual loads are identical, so that the stage is perfectly balanced. It will also be assumed that the valves have square-law dynamic characteristics, for then only second harmonic distortion is introduced in the individual sides. The circuit is that of Fig. 2 and the output transformer referred to below is, of course, in a subsequent stage.

The first thing to notice is that the fundamental components of the anode currents, being in phase with the input voltages, are equal and opposite in the common HT lead and in the common cathode circuit. They cancel completely, therefore. The second harmonic components are in phase at these points, however, and consequently combine to produce an alternating voltage across any impedance in the cathode circuit. They cancel in the output transformer, where



the fundamental components add.

If the cathode resistance  $R_c$  is adequately by-passed the second harmonic distortion of the individual valves balances in the output transformer. The stage as a whole then introduces no distortion.

If  $R_c$  is not by-passed a voltage at twice the input frequency is developed across it and is applied in the same phase to the grids of both valves. In effect, therefore, the grid-cathode voltage of each valve consists of two voltages—one of frequency  $f$  and the other of frequency  $2f$ . As the valves are non-linear sum and difference frequencies are formed in the output, and they are  $f$  and  $3f$ . The one at the fundamental combines with the direct fundamental component and so changes its magnitude somewhat, but the other appears in the output as a third harmonic.

A second harmonic of the second harmonic component of the grid-cathode voltage is also formed—this is a fourth harmonic of the input. It flows through  $R_c$  and so produces a fourth harmonic component in the grid-cathode voltage. By sum and difference this produces 5th and 7th harmonics.

The net result of  $R_c$  is to produce in the anode currents of both valves an infinite series of harmonics of the input frequency. The even-order harmonics all cancel in the output transformer, but add in  $R_c$ , while the odd-order harmonics cancel in  $R_c$  and add in the output transformer.

### Output Distortion

In the ideal push-pull stage the effect of omitting a by-pass condenser to  $R_c$  is to produce in the output a series of odd-order harmonics where there were none before. Distortion is, therefore, increased. The important practical point, of course, is the amount of the increase. Unfortunately, it is only possible to calculate this easily in certain special cases. It is worth attempting it, however, for it gives a good indication of the order of magnitude of the effect, and so enables one to make a good guess at the results in a practical case in which exact calculation is too laborious to be worth while.

Equation (3) in the Appendix gives the third harmonic distortion ratio for the case when the

dynamic characteristic of the valve can be expressed by a quadratic equation. It is strictly applicable only to the case of a resistance-coupled stage, for no account has been taken of the coupling of the two anode circuits by a transformer. The subsequent combination of the outputs in a succeeding stage is considered, however.

The third harmonic distortion is expressed in terms of two symbols  $\alpha$  and  $\beta$ , and it may be as well to consider their meaning. The former is merely the ratio of second harmonic to fundamental in each valve acting independently. If the valve is completely linear  $\alpha$  is zero and there is no distortion in the stage at all. The other term,  $\beta$ , is a number, since  $A_1$  has the dimensions of a conductance and is really the effective value of the mutual conductance of the valve at the fundamental frequency. It forms a kind of coupling factor in the production of third harmonics from the second. It is zero when the cathode resistance is zero, or shunted by a large capacity, and there is then no third harmonic production.

Similar expressions to equation (3) can be determined for the higher order odd harmonics. Their percentage is always less than that of the third, however, so that if the design is carried out to make the third negligible, they also are negligible.

As one example of the magnitude of the effect, the case of the penultimate stage of the *Wireless World* Push-Pull Quality Amplifier has been examined. MHL4 valves are used with a cathode resistance of 500 ohms. Over a range somewhat greater than that covered by the maximum signal input it was found that the dynamic characteristic could be represented almost exactly by the necessary quadratic equation, the actual and calculated curves being indistinguishable on a normal scale of plotting. The values of  $A_1$  and  $A_2$  deduced from the curves are respectively 0.56 and 0.0086. The normal maximum input is 3.5 volts peak per valve, so that  $\alpha = 0.0051$  and  $\beta = 0.72$ . This gives the third harmonic ratio as  $4.66 \times 10^{-6}$ .

This is quite negligible, and is likely to be much smaller than the second harmonic in the out-

put when the stage is not perfectly balanced, as it will not be in practice. Such lack of balance will not affect the amount of third harmonic appreciably because it depends on the sum of the individual second harmonics of the two valves, whereas the second harmonic in the output depends on their difference. The sum is only changed by a small amount if the two sides of the amplifier are slightly different, but the difference changes a lot.

### Harmonic Relationship

The value of the term  $\beta$  must lie between 0 and 2. It is easy to show that even with the maximum value of  $\beta$  the simple equation (4) is sufficiently accurate for degrees of second harmonic distortion up to at least 20 per cent. ( $\alpha = 0.2$ ). Thus, for 20 per cent. second harmonic per valve, equation (3) gives the third harmonic as 2.24 per cent., while equation (4) makes it 2 per cent. In practice,  $\beta$  is usually less than unity and it is not customary to allow the second harmonic per valve to be anything like 20 per cent. In nearly all practical cases, therefore, the simple equation (4) is sufficiently accurate.

In all ordinary cases of Class A push-pull the third harmonic ratio will not exceed  $\alpha^2/2$ , and will usually be less. 10 per cent. distortion per side is probably as much as is ever allowed in Class A; this makes  $\alpha = 0.1$  and the third harmonic ratio cannot exceed 0.005, or 0.5 per cent. In actual fact, it will rarely be more than one-half of this, because  $\beta$  will be around unity.

In applying these results it must not be forgotten that no allowance has been made for valves having characteristics only expressible by a cubic equation. Such valves introduce third harmonic distortion directly and tetrodes and pentodes are the most obvious examples. When used in push-pull, however, the load impedance is always chosen so that the direct third harmonic distortion is a minimum, for the higher second harmonic distortion then obtained balances in the push-pull connection. Push-pull, in fact, offers little advantage unless the distortion per valve is predominantly second harmonic. It is reasonable to suppose, therefore, that the analysis given

above applies at least approximately to most normal cases.

It is safe to say that in any push-pull stage in which the second harmonic distortion per side is less than about 5 per cent., the odd-order harmonic distortion introduced by the omission of a cathode resistance by-pass condenser is negligible. As the omission of the condenser considerably improves the balance of the stage and is also economical, it is good practice not to use a condenser.

### When to Omit Condenser

It is safe to say that a by-pass condenser need not be used in any normal Class A stage. In a Class AB stage which is driven fairly lightly, so that in reality it is only just Class AB, it is usually safe to omit the condenser. The total distortion may increase slightly, or what is really the same thing, the undistorted output may be slightly less. It will sometimes be better to make up for this by increasing the anode voltage and current slightly, provided that the valves are not already running at their limit, than to use a condenser.

With true Class AB the distortion per valve is fairly high, and a by-pass condenser on the cathode resistance is usually advisable. If Class AB is being utilised to the limit, however, in order to obtain the maximum possible output, then cathode bias itself is not permissible and the question of a by-pass condenser does not arise. This is always true of Class B; both Class B and "heavy" Class AB demand a fixed bias source because there is a large fluctuating anode current. Cathode bias is only allowable when the mean anode current is substantially independent of the signal input.

To sum up, in all push-pull stages but the output it is usually desirable to use a common cathode bias resistance without a by-pass condenser because of the self-balancing action then obtained. Distortion is increased by a negligible amount. In a Class A and "light" Class AB output stages the by-pass condenser can also normally be omitted with advantage. It should not be omitted, however, in a true Class AB stage. The omission of the condenser makes

it less important to use matched valves, and in the case of a resistance-coupled stage it becomes more important to match the coupling resistances than the valves.

### APPENDIX

#### The linear condition

(Circuit of Fig. 1).

$$\frac{i_{a2}}{i_{a1}} = \frac{\mu_2 \{R_{a1} + R_c (2 + \mu_1)\} + n^2 R_L (\mu_2 - \mu_1)/4}{\mu_1 \{R_{a2} + R_c (2 + \mu_2)\} + n^2 R_L (\mu_1 - \mu_2)/4} \quad \dots (1)$$

where

$\mu_1$  and  $\mu_2$  = amplification factors of  $V_1$  and  $V_2$  respectively,  
 $R_{a1}$  and  $R_{a2}$  = anode A.C. resistances of  $V_1$  and  $V_2$  respectively,  
 $i_{a1}$  and  $i_{a2}$  = alternating anode currents of  $V_1$  and  $V_2$  respectively,  
 $R_c$  = cathode bias resistance,  
 $n$  = ratio of primary/secondary turns on transformer,  
 $R_L$  = secondary load resistance.

(Circuit of Fig. 2).

$$\frac{E_2}{E_1} = \frac{R_2}{R_1} \frac{\mu_2 e_2 \{R_{a1} + R_1 + R_c (1 + \mu_1)\} + \mu_1 e_1 R_c (1 + \mu_2)}{\mu_1 e_1 \{R_{a2} + R_2 + R_c (1 + \mu_2)\} + \mu_2 e_2 R_c (1 + \mu_1)} \quad \dots (2)$$

where

$e_1$  and  $e_2$  = input voltages of  $V_1$  and  $V_2$  respectively  
 $E_1$  and  $E_2$  = output voltages of  $V_1$  and  $V_2$  respectively,  
 $R_1$  and  $R_2$  = anode circuit load resistances of  $V_1$  and  $V_2$  respectively (each equals the coupling resistance in parallel with the following grid leak).

Other symbols are the same as for equation (1).

#### The non-linear condition

The valve dynamic characteristic is assumed to be expressed by

$$I = a_0 + a_1 E_g + a_2 E_g^2$$

where  $I$  = direct anode current,

$E_g$  = grid bias.

$$\text{Inserting } I = I_{D0} + i$$

$$E_g = E_{D0} + e_g$$

expanding by Taylor's theorem and extracting the alternating components gives,

$$i = (a_1 + 2a_2 E_{D0}) e_g + a_2 e_g^2$$

where  $i$  = alternating anode current,

$E_{D0}$  = operating value of grid bias.

When  $R_c = 0$ , the ratio of second harmonic to fundamental components in each valve is  $\alpha = e_g A_2/A_1$

When  $R_c$  is finite, the ratio of third harmonic to fundamental in the output of the push-pull stage is

$$\gamma = \frac{\alpha^2 \beta (0.25 + 0.078 \alpha^2 \beta^2 + 0.041 \alpha^4 \beta^4 \dots)}{1 - \alpha^2 \beta (0.75 + 0.156 \alpha^2 \beta^2 + 0.068 \alpha^4 \beta^4 \dots)} \quad \dots (3)$$

where  $\beta = \frac{2}{1 + I/2A_1 R_c}$  provided that  $\alpha \beta < 1$

When  $\alpha \beta$  is small equation (3) reduces to

$$\gamma = \alpha^2 \beta / 4 \quad \dots \dots \dots (4)$$

If  $I$  and  $i$  are expressed in mA,  $R_c$  must be in k $\Omega$ .

### Books issued in conjunction with "Wireless World"

	Net Price	By Post
FOUNDATIONS OF WIRELESS. Fourth Edition, by M. G. Scroggie ... ..	7/6	7/10
TELEVISION RECEIVING EQUIPMENT, by W. T. Cocking ... ..	10/6	10/10
RADIO LABORATORY HANDBOOK, by M. G. Scroggie. Second Edition ... ..	12/6	12/11
WIRELESS SERVICING MANUAL, by W. T. Cocking. Sixth Edition ... ..	7/6	7/10
HANDBOOK OF TECHNICAL INSTRUCTION FOR WIRELESS TELEGRAPHISTS, by H. M. Dowsett and L. E. Q. Walker. Seventh Edition ... ..	30/-	30/7
RADIO DATA CHARTS. Third Edition, Revised by J. McG. Sowerby, B.A., Grad. I.E.E. ... ..	7/6	7/10
RADIO INTERFERENCE SUPPRESSION, by G. W. Ingram ... ..	5/-	5/4
LEARNING MORSE. 335th thousand ... ..	6d.	7½d
INTRODUCTION TO VALVES, by F. E. Henderson ... ..	5/-	5/4
RADIO WAVES AND THE IONOSPHERE, by T. W. Bennington ... ..	6/-	6/3

Obtainable from leading booksellers or by post from  
 ILIFFE & SONS LTD., Dorset House, Stamford Street, London, S.E.1

# RAILWAY COMMUNICATIONS

## A Frequency - Modulated Carrier - Current System

From the point of view of communications, a moving train is unlike any other mobile station, in that "wired wireless" or carrier-current telephony may be considered as a possible alternative to true radio. In America, where the "inductive" system here described was developed, strong arguments have been adduced in favour of non-radiating methods of communication for use on railways.

**T**HE application of telecommunications to moving trains, partly as an aid to operational efficiency and partly as a safety measure, has been closely studied by railway and communication engineers in America over a long period of years, and equipment for the purpose has now reached quite a high state of development.

It may be of some interest briefly to examine the minimum requirements for a train communication system, if it is to be a worth-while aid to the efficient operation of a railway. First, telephonic communication to and from a moving train over an adequate distance is essential, together with facilities for inter-communication between trains on the same, or adjacent, tracks, but only over a short distance. Secondly, the traffic controller should be able to break into any conversation in order to pass on an urgent and important operational message. Inter-communication between engine crew and guard on a train is also required.

### Inductive System

No doubt these requirements could be met in more than one way, but it must suffice, for the purpose of this article, to consider only the solution provided by the Union Switch and Signal Company, of Pennsylvania, with which is associated in this country the Westinghouse Brake and Signal Company, Ltd. Described as the Union Inductive Train Communication System, and based on the carrier-current or wired wireless principle, it is called an inductive system because the path of the signal from sending to receiving points includes two or more inductive links.

This is well illustrated in the accompanying schematic drawing showing the mechanism of transmitting a signal from a guard's

van to a locomotive, the location of the various inductive links being easily recognised. The guard's van may be part of the same train or it may be part of an entirely different train; the principle of operation is the same. Likewise a traffic office could take the place of either the locomotive or the guard's van.

Briefly stated, the carrier current output from the transmitter is induced into that portion of the railway track over which the vehicle is passing by means of a properly matched transmitting loop. The track rails, vehicle and adjacent ground form a load circuit for the loop, and maximum transference of energy results. The magnetic fields generated by the loop and the load circuit thread any adjacent telegraph or signalling wires paralleling the track and induce carrier-frequency currents in them.

Because the rails are poorly insulated and rail section joints very imperfectly bonded the signals induced in them suffer heavy attenuation, but those induced in the track-side wires may travel very considerable distances, since

will generally be of sufficient intensity to re-induce currents in the track rails, so enabling communication to be effected with trains in the vicinity. It is apparent that under some conditions very high receiver sensitivity may be required, and in order to ensure satisfactory reception in the most awkward locations a maximum sensitivity of 1 microvolt is available in all receivers.

As signal currents have to be injected into lines and conductors which are subject to wide variations in distributed impedance the best operation is obtained with carriers of fairly low frequency. When FM is used the Union system is operated on any frequency lying between 10 and 250 kc/s, a typical installation usually providing for two-channel working on perhaps 80 and 120 kc/s respectively. Most of the rolling stock and possibly all the traffic control stations would be equipped for transmission and reception on both channels, but as a rule the routine messages and inter-train communications are confined to one channel only, the other being reserved for emergency traffic and

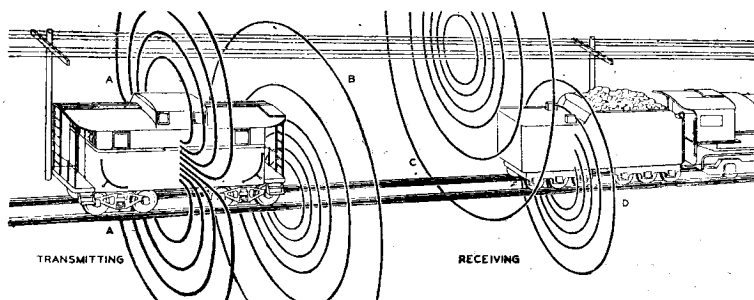

Schematic diagram showing the mechanism of transmission and reception by the Union Inductive Train Communication equipment. The two vehicles shown may be part of the same train or part of an entirely different train.

these are usually either telegraph or telephone lines and consequently are well insulated.

At distances of the order of 100 miles signal currents in the wires

to enable a fairly free channel to be available for the traffic controllers to break in on a conversation between trains.

Although a single receiver



### Railway Communications—

could, no doubt, be used for simultaneous reception on two different frequencies when one is for emergency use only, the Union system favours the more straightforward practice of providing a separate receiver for each channel. Thus the equipment for two-channel working has two independent receivers but only one transmitter, the latter being capable of rapid adjustment to whichever channel is required.

is inherently bad, and partly because this method of modulation has the least disturbing effect on varying amplitude signals such as telephone and telegraph services along the track. A speech frequency of 6,000 c/s is used; that is, a maximum of 3,000 c/s either side of the nominal carrier frequency. As this enables speech frequencies of from 200 to 2,750 c/s to be impressed on the carrier it provides good speech quality. Transmitters and receivers fol-

The normal working distances covered by the equipment illustrated here is approximately five miles between trains and up to 120 miles when communicating with a fixed traffic control. The longer distances in the latter case can be accounted for by the higher carrier power that can be injected into the line wires from a fixed station, where either a direct connection can be made, or, as is more usual, closer coupling effected by running some radiating wires parallel to the track-side wires for a hundred feet or so.

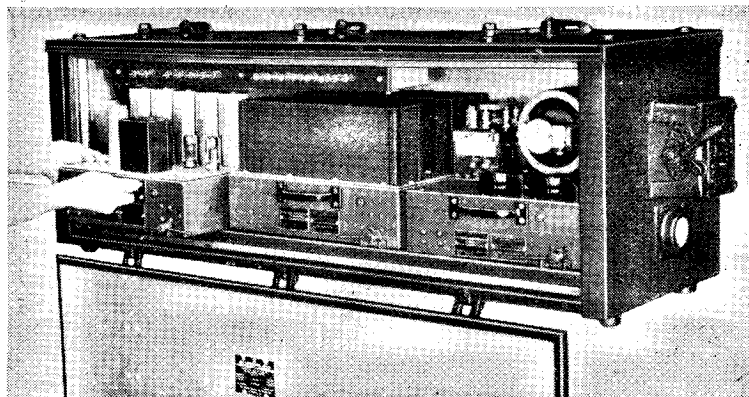

A single-channel train communication equipment comprising transmitter, receiver and power supply units. Interconnection is by means of plugs and sockets giving easy replacement of a faulty unit. The container has shock-absorbing mountings.

The equipment is relay operated by remote control, thus enabling the bulky part of the equipment, comprising receivers, transmitters and power supplies, to be accommodated in a convenient out-of-the-way part of the vehicle. Only the remote control unit with its telephone hand-set (which embodies a microphone and press-to-transmit switch) and a loudspeaker need be accessible to the users. The change-over switching is so arranged that the loudspeaker is always connected to the receiver tuned to the channel not being used for transmission at the time. If, for example, the channel selector switch were set for operation on 80 kc/s the telephone hand-set would be connected to the 80-kc/s receiver and the loudspeaker to the 120-kc/s set.

### Advantages of FM

Frequency modulation is now used in the Union equipment partly because it provides a better signal-to-noise ratio under conditions where electrical interference

low normal radio practice for FM equipment, but low-impedance transmitting loop and receiving coils take the place of the usual aerial systems. The four principal units; namely, transmitter, two receivers and power supply, are housed in a stout waterproof container hung on shock-absorbing mountings. Units are readily interchangeable with similar items in other equipments, the design permitting quick release and replacement of any faulty units. Plugs on the back of each chassis marry with corresponding sockets on the container so that when a unit is pushed into place interconnection between units is made automatically. The turn of a lever on the front of each chassis securely locks the units in the container.

Power is provided through a dynamotor from a bank of accumulators in the case of a guard's van installation and from the headlight electric supply in the case of a locomotive. This is a standard fitting on American locomotives which usually have a 32-volt DC supply for this purpose.

## POST-WAR FREQUENCY ALLOCATION

### Guiding Principles

AT a recent discussion meeting of the Radio Section, Institution of Electrical Engineers, fears were expressed that expediency might possibly prevent the allocation of frequencies on a purely rational and scientific basis. If that happened, it would be more than ever necessary to make the best possible engineering use of channels.

On the guiding principles of allocation, it was agreed that priority should be given to those services concerned with safety of life and with communications involving mobile stations, particularly ships and aircraft, for which no system other than radio is available. Further, the mobile station should have a first call on the best frequencies, as it is inherently more restricted in the equipment and power that it can use than is the fixed station. Transoceanic telephony should also rank high, as there is at present no satisfactory alternative to radio.

Narrower telegraphy channels, drastic reduction of bandwidths generally, closer frequency tolerances, better use of directional properties of transmitting aeri-als, and extended use of the principle of relaying over paths subject to favourable propagation conditions were all advocated as making for more effective use of radio channels. In connection with relaying, it was urged that provision of direct services between all the important centres of the world was inefficient or impracticable; the question of an international relay network was considered.

Dr. R. L. Smith-Rose, who opened the discussion, said, in summing up, that ultimately it might be necessary to accept the principle that radio should be restricted to those services for which a metallic connection was impracticable.

# Angles on **BRIMAR PRESTIGE**

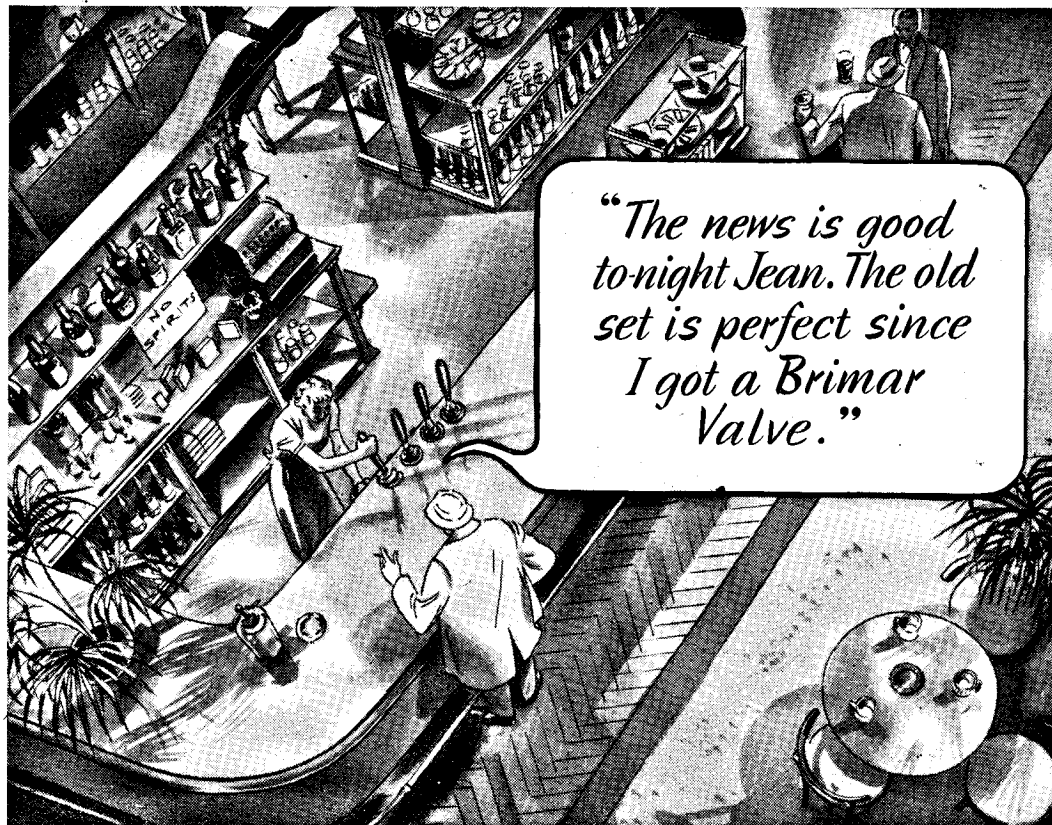

*You can use Brimar Valves with the complete confidence that you will get peak performance from them. Valves are still in short supply, but you may be able to get the Brimar Valve you require.*

# BRIMAR

(BVA)

# VALVES

**STANDARD TELEPHONES AND CABLES LIMITED, FOOTSCRAY, SIDCUP, KENT.**

THREE SPOTS OF DIRT...



Just as Tojo and all his gang have shown how a little bit of blight can upset the peaceful system in this world so can an imperfect transformer quite easily gum up the works of any electrical system. A mere few specks of dust nesting in the wrong place can make you wonder if you or the man who sold you the new spotwelder is daft . . . or both!!

It's a good thing to remember that every Parmeko transformer is "pressure impregnated". What does all that mean you ask? Well, to revert to the vernacular it means there's no muck in it now nor never. Makes a big difference - you'd be surprised!

The design of electronics equipment has grown into an exact science but even now there are many problems in Transformer design which, if not put in the hands of an experienced Transformer expert, can retard the performance of any equipment. The many years of experience during which Parmeko Ltd. have specialised in Transformers enables us to recognise and control any possible source of trouble.

**PARMEKO LTD., LEICESTER.**  
Makers of Transformers.



Clear as a Crystal

AND HERE IS THE REASON . . .

. . . the answer has been found in Bullers Low Loss Ceramics to the problem of Dielectric Loss in High Frequency circuits.

Years of Laboratory research and development have brought these materials to a high degree of efficiency. To-day they are in constant use for transmission and reception, and play a vital part in maintaining communications under all conditions.



Made in Three Principal Materials

**FREQUELEX**  
An Insulating material of Low Dielectric Loss, for Coil Formers, Aerial Insulators, Valve Holders, etc.

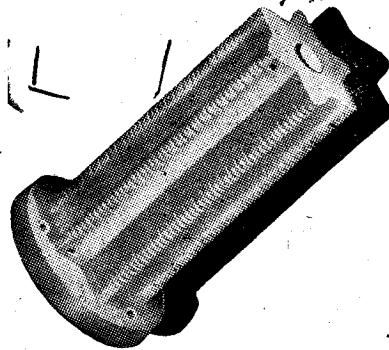

**PERMALEX**  
A High Permittivity Material. For the construction of Condensers of the smallest possible dimensions.

**TEMPLEX**  
A Condenser material of medium permittivity. For the construction of Condensers having a constant capacity at all temperatures.

**BULLERS, LTD.**  
THE HALL, OATLANDS DRIVE, WEYBRIDGE, SURREY

Telephone : Walton-on-Thames 2451  
Manchester Office : 196, Deansgate, Manchester.

**Bullers**

LOW LOSS CERAMICS

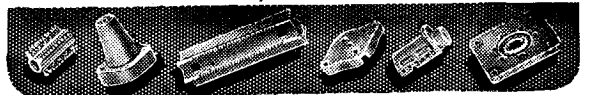



# SUNSPOT MINIMUM

## Has It Already Passed?

T. W. BENNINGTON

IN *Wireless World* for February, 1944, was an article entitled "1944: Sunspot Minimum Year," in which were discussed some of the solar phenomena which occur at the end of one solar cycle and the beginning of the next. It was pointed out that, though it was impossible to say with any certainty when the minimum of the current solar cycle would be reached there were definite indications that it was fast approaching, and that it might occur during 1944. In the July issue was a report of the indications put forward by Dr. A. H. Shapley, who, using formulæ derived by Brunner, found that the minimum of the cycle might occur in 1944.9 (using the decimal date system). He was careful to add that this date should be regarded rather as an indication than as a definite prediction.

As 1944 is now well past it may be interesting to see what variations in solar activity did take place during that year. But it should first of all be stated that, because the solar activity fluctuates widely from day to day, it is impossible to know that the minimum has actually been reached until some time after that event. The solar activity—as evidenced by the size and frequency of appearance of the sunspots, and in other ways—may temporarily increase, only to decrease again to a new low level. Nevertheless the solar happenings of recent months do indicate that the minimum is possibly already past, and that the sun's activity has begun its rise towards the next solar maximum, which may occur in four or five years' time.

### Effects on Radio

Before going into any details about the solar activity it may—at the risk of being repetitive—be as well to reconsider the connection between it and the science of radio communication. Why should the radio man be at all interested in these solar phenomena?

Well, it is because of the fact that the short radio waves are dependent for their propagation over long distances upon the state of the ionosphere, and that the ionosphere is produced—at least largely if not entirely—by the ultra-violet light radiated by the sun. The degree of ionisation of the gases of the ionosphere therefore changes with the variation of solar activity, reaching high levels at the maximum of the solar cycle and low values at the minimum. When the ionisation is high then higher frequencies (shorter waves) must be used for a given distance for good propagation by the ionosphere, and when low ionisation prevails the lower frequencies (longer waves) must be used. Consequently, as the solar activity increases again we may expect to have to make more use of higher short-wave frequencies than for the past few years, perhaps to bring into use high frequencies not hitherto used and to discard some of the lower ones.

To return to the recent variations in solar activity. The sunspot activity is measured and recorded by means of a system of "relative sunspot numbers," which takes into account the number of sunspot groups and also the number of individual spots observed at different observatories. This "relative number" may thus be regarded as a measure of solar activity as evidenced by the sunspots. The Table gives the yearly means of this number for each year since 1937, the year of the last solar maximum. It is seen that the activity has decreased year by year from then,

Yearly Means of Relative Sunspot Numbers.		
Year	Sunspot Number	
1937	..	114.4
1938	..	109.6
1939	..	88.8
1940	..	67.8
1941	..	47.5
1942	..	30.6
1943	..	16.3

so that the mean for 1943 was at the low value of 16.3. Although the yearly mean for 1944 is not yet available it was probably about 10.0. The yearly mean for 1933—when the previous minimum occurred—was 5.7.

### Lowest Level?

During the first few months of 1944—judging from the *monthly* means of the sunspot numbers so far available—the solar activity dropped to even lower levels than had occurred towards the end of 1943; indeed, during February and April there were practically no sunspots observable. But in August there was a considerable increase, and up to the end of December this increase had been *fairly* consistently maintained. So that as far as the period 1943-44 is concerned there was a minimum in the activity at *about* 1944.5. Was this the actual minimum of the sunspot cycle, or may the activity fall to a new low level? That is a question which only time can answer, but it may at least be said that there is a distinct probability that the minimum is indeed already past, and we are definitely on the way towards a new maximum.

During December there appeared a major group of sunspots—the first *large* group to be observed for many months—and this crossed the sun's central meridian on December 14.3. It was in solar latitude 22 deg. South, and this fact indicates that it might properly be considered as belonging to the new cycle. For towards the end of a cycle the spots belonging to the old cycle appear in low latitudes—around 8 deg.—but there also begin to appear sunspots in high latitudes (20 deg.-40 deg.), and these are considered to belong to the new cycle. These high-latitude spots have been appearing for the past eighteen months, and with increasing frequency during that period.

As was explained in the *Wireless World* article first referred to, the magnetic field of the sunspots undergoes a reversal of polarity at



**Sunspot Minimum—**

the end of a cycle, and the Mount Wilson Observatory has observed this reversal of polarity to be occurring in the case of the high-latitude spots for some time past. There are thus the three facts (a) the reversal in magnetic polarity of certain sunspots which has been observed for some time, (b) the observation with increasing frequency for the past eighteen months of high-latitude sunspots, (c) the increase in sunspot activity which commenced last August, which would seem to indicate that the solar activity has now started a general increase towards the maximum.

**Ionosphere Disturbances**

Incidentally readers of *Wireless World* will no doubt remember that the sunspots, besides producing a rise in the ionisation of the upper atmosphere such as gives rise to good propagation of short waves, sometimes also appear to be responsible for temporary ionosphere disturbances, radio fade-outs and magnetic storms. They will therefore be interested to know that, following the passage across the sun's central meridian of the large sunspot group on December 14.3, there was a considerable disturbance in the earth's magnetic field on December 16th-17th. A number of sudden radio fade-outs also occurred, and then ionosphere conditions were very "stormy" from December 16th-20th.

# FREQUENCY CONTROL IN RADIO HEATING

**A**LTHOUGH frequency control may be uneconomical in low-powered radio heating units it offers many advantages in larger installations. The hot and steamy atmosphere of a moulding shop is not the best environment for RF generators, and there is much to be said for the use of a separate RF "power house" with connection by transmission lines to operating heads adjacent to each press. Alterations in the layout of the press shop are more easily carried out with this arrangement, and the possibility of damage is limited to a comparatively small unit.

The successful utilisation of long transmission lines is dependent on correct termination, and this is facilitated if the "work circuit" is tuned to the generator frequency. An automatic device for compensating for capacity variation due to changes in dielectric constant of the material during heating has been described recently\* by R. W. Gilbert, and the circuit is shown in the figure. One of the parallel plates between which the preform is placed is movable, and the distance of separation is adjusted by a reversible electric motor

controlled by a relay in the output circuit of a phase-sensitive valve bridge. The input to the bridge is obtained through a separate transmission line to include phase shifts through the power transmission line caused by detuning of the work circuit. The phase deviation is in opposite directions on each side of resonance, and the polarity of the DC output—normally balanced to zero—also depends on whether the load is effectively inductive or capacitive. Not only does the plate separation adjust itself to allow for a rise in dielectric constant in the work during heating, but it also compensates for initial differences in the preforms.

In practice the movement of the top plate during the heating cycle is found to be about one-tenth of the preform thickness, and a plate speed of two to four inches per minute has been found satisfactory for thicknesses up to four inches. If the air space does not exceed one-fifth of the preform thickness, uneven heating due to fringing of the field is not excessive. Danger of flash-over in the generator due to mismatching while the initial adjustment of the work circuit is taking place must be guarded against by using tank circuit condensers with a factor of safety above normal. Risk of damage through starting up without a preform between the plates is lessened by limit switches on the plate traverse; the driving mechanism is also provided with a disengaging gear which operates if the plate makes contact with the preform.

To ensure that the generator is always fully loaded the presses are operated in rotation, and an interlocked contact system ensures that only one operating head at a time is connected to the generator.

If the proposed allocation of frequency bands for radio heating materialises, the ability to operate on a fixed frequency would in many cases save the cost of screening and its attendant working restrictions.

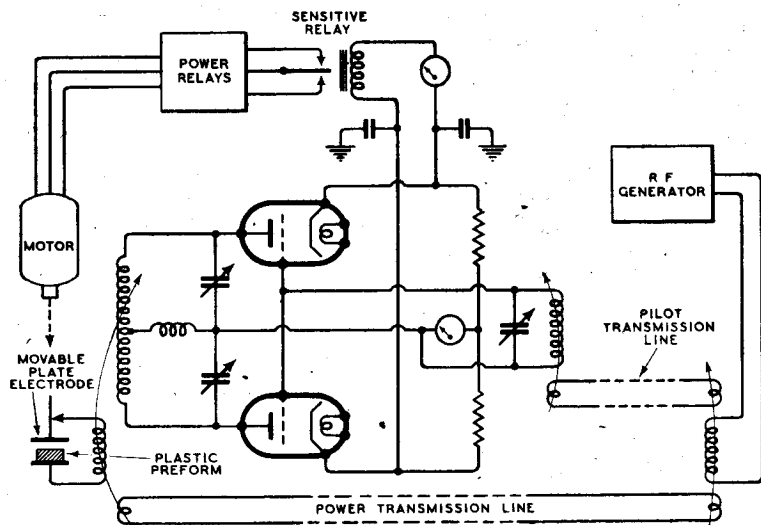

Essential circuit of frequency control mechanism for radio heating.

\* *Electronics*, December, 1944.

# TEACHING MATHEMATICS

## Plea for Improved Methods

By J. J. DURACK,  
M.A., F.Inst.P.

THE report on the above subject recently issued by a combined committee of members of the Institute of Physics and the Mathematical Association provides very interesting reading. Coming from such a body of experts, it deserves the serious attention of practical men.

There are, in the report, some statements with which many will immediately disagree. In the first line we read, "Some knowledge of mathematics is essential to every experimental physicist." And later, "A student whose mathematical ceiling is really unduly low would probably be well advised to transfer his interest to some other branch of science."

Now Faraday had no mathematical knowledge. We may read through the whole of his "Experimental Researches" without finding a single mathematical symbol. And how much would we miss to-day if Sir Humphrey Davy had advised him to transfer his interest from physics to some other science. We might still be without electricity for light, heat and power.

Let us not, however, rush to the other extreme and imagine mathematics a hindrance, as many may do after reading the report of Prof. Howe's I.E.E. speech in *Wireless World* for July, 1944. Prof. Howe told his audience that "the most outstanding achievements in the early days of wireless telegraphy were accomplished in spite of principles and theory."\*

The most outstanding achievement in wireless telegraphy was undoubtedly Hertz's discovery of electromagnetic waves which had been predicted some twenty years previously by Maxwell on purely mathematical grounds. Convinced of the soundness of Maxwell's theory Hertz deliberately set out to produce and detect these waves.

Discoveries in science are not made by haphazard experimentation but by looking for something.

\* It should perhaps be noted that this statement, without context or explanation of the circumstances in which it was made, may give a misleading impression of Prof. Howe's real views on the matter. [Ed.]

Theory provides the road along which the experimenter may travel and the greater his mathematical attainments the swifter his progress will be. Faraday's genius built up a geometric picture of lines of force which served him as a working theory. This picture, in mathematical dress, forms the basis of Maxwell's theory of electricity and magnetism.

The distrust of mathematics among practical men is fairly widespread. From time to time we are treated to tales of mathematical "errors" like the story of Tait and the golf drive. The errors, however, are not in the mathematics but in their misapplication. An erroneous assumption will, in the long run, lead to a false conclusion though the intermediate steps be perfectly correct.

In addition to mistrust we find amongst practitioners a fear, or hatred brought on by fear, of mathematics, however simple. I know, from personal experience, that this fear can sometimes be dispelled and interest stimulated by taking quite a complicated formula and explaining each term in simple language. A neat approach on these lines was taken by Martin Johnson with Maxwell's electromagnetic equations in *Wireless World*, Feb.-July, 1943.

In the Committee's report it is rightly stressed that theory and practice should go hand in hand, but little is said of the manner of conducting classes. The present system of the university lecturer is an hour's address to a large class, after which he collects his papers and departs. More than half the students gain little or nothing from such lectures. Classes should be limited to a dozen students, the last quarter-hour devoted to question and answer and the students given one or two problems to work out for themselves, the lecturer's solutions being given at the beginning

of the next lecture. In the words of the late Lord Rayleigh, problems, problems and still more problems, form the royal road for mathematical progress.

The minimum course set out in the report is:—

Algebra. Permutations and combinations, the binomial theorem.

Plane trigonometry. Solution of triangles.

Geometry. Cartesians in two dimensions, conic sections.

Calculus. Differentiation and integration of simple algebraic and trigonometric functions.

Mechanics. Statics, dynamics, hydrostatics, composition of vectors. Newton's laws, units and dimensions.

Formidable as this syllabus may appear to the practical man there are, I think, for the radio-electrician three important subjects missing. The limitation of geometry to two dimensions is decidedly harmful. We learn to think in two dimensions and most of our problems are three-dimensional. I once gave the following puzzle to a senior wrangler. "Make four equilateral triangles with six matches which must not be broken." At the end of half an hour he told me it could not be done. A working carpenter did it in five minutes. The wrangler's mind worked on the flat, the carpenter's in space.

Solid geometry should, I hold, go apace with plane geometry and the simplest and most natural method of treating solid geometry is with vector algebra, not cartesians. This course might possibly be replaced by one of practical carpentry or mechanics.

The second subject I would add is logarithms. There are occasions when our slide rule is not sufficiently accurate.

Logarithms also serve as an introduction to my third subject—imaginaries, invaluable in the treatment of alternating current. With a foundation of elementary logarithmic theory sufficient knowledge of imaginaries for practical purposes can be acquired in a few hours.

# RADIO DATA CHARTS—18

## Transmission and Phase Shift of RC Couplings

THE simple and familiar RC coupling is shown in Fig. 1. Let the output voltage of the first valve be  $E$ , and the voltage across the resistance  $R$  be  $e$ . Then:

$$\frac{e}{E} = \frac{R}{R - jX} = \frac{R^2 + jRX}{R^2 + X^2} \quad (1)$$

Where  $X = 1/2\pi fC =$  the reactance of the condenser at the frequency,  $f$ , in which we are interested. Taking the modulus of (1), we find

$$\left| \frac{e}{E} \right| = \frac{R}{\sqrt{R^2 + (1/2\pi fRC)^2}} \quad (2)$$

and this we may call the transmission factor. Thus if at any frequency the transmission factor is 0.9, then  $e = 0.9E$ . We may also be interested in the phase change through the coupling, and we can write this down at once from (1). It is

$$\phi = \tan^{-1} \frac{1}{2\pi fRC} \quad \dots (3)$$

Thus we see that both the transmission factor and the phase shift depend only on  $2\pi fRC$ , so that an abac which multiplies  $f$ ,  $R$ , and  $C$  together can have scales graduated in terms of transmission factor and phase shift. This has been done, and the result is presented here. It has been left to the user to multiply  $R$  and  $C$  together. Given the value of  $RC$ , it is only necessary to join the corresponding point on the RC scale to the frequency required, and the transmission factor and phase shift are given simultaneously at the point where the ruler cuts the right-hand scales.

The uses of the chart will be obvious to anyone engaged in the design of audio amplifiers, but it may nevertheless be useful to remark a few of the more obvious uses. Besides the usual application to the design of audio amplifier couplings, the chart can be used for calculating bass cut in tone controls which are of this type. It is sometimes desirable—especially in high power public address systems—to limit the bass response of the amplifier to avoid overloading the speaker(s). If

By J. MCG. SOWERBY,  
B.A., Grad.I.E.E.

(By permission of the Ministry of Supply)

the required diminution in response at some frequency is fixed, the chart can be used to find the corresponding RC value. If this response is required to be variable, either  $R$  or  $C$  may be varied and the chart will perform the required calculations from which several response curves corresponding to different settings of the control can be laid off in a few minutes. The chart may also be of assistance in determining suitable constants for loudspeaker dividing networks of the simplest possible RC type, though the more complicated networks covered by Chart No. 10 in this series would give a better performance. In designing amplifiers for electro-medical and CRT recording work,

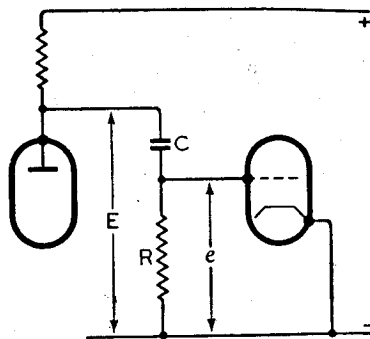

Fig. 1. Essential elements of a resistance-capacity coupling.

a very low frequency response (down to 1 or 2 c/s) is sometimes required, and the frequency scale of the chart is consequently extended to cover these requirements.

The phase-shift scale will, it is hoped, be useful to those concerned with negative feedback amplifiers. Nyquist's<sup>1</sup> criterion of stability in a feedback amplifier demands<sup>2</sup> that the loop gain of an amplifier (i.e. input, through amplifier, through feedback network, and back to input) shall be

less than one when the fed-back signal is in phase with the input signal. This demand may not be met at some low, or some high frequency; and if it is not, then oscillation or other instability will result. At the low frequency end, most of the phase shift is usually contributed by the couplings, and it is hoped that the information given by the chart will save time in calculations concerning possible instability in such amplifiers. The chart may also be of use when frequency selective negative feedback lines are used.

**Example 1.**—A three-stage high-gain amplifier for oscillographic work (gain 100,000 times at 1,000 c/s) has two couplings whose RC value (or time constant) is 0.025, consisting of 0.1  $\mu$ F condensers and 0.25 megohm grid leaks. What is the gain and phase shift at 30 c/s?

Join 0.025 on the RC scale to 30 c/s. The ruler cuts the transmission factor scale at 0.979, and the phase shift scale at 11.95°. Hence the amplifier gain at 30 c/s will be  $0.979 \times 0.979 \times 100,000 = 95,800$  (4 per cent. low) and to all intents and purposes the phase shift will be 24°.

**Example 2.**—A feedback amplifier is required to have a phase shift not greater than 5° per stage at 50 c/s. What is the necessary RC value, assuming that all the phase shift takes place in the couplings?

Join 5° on the phase shift scale to 50 c/s and the ruler cuts the RC scale at 0.0364 which is the required minimum value. Condensers of 0.075  $\mu$ F and grid leaks of 0.5 megohm might well be suitable for the couplings.

<sup>1</sup>H. Nyquist, "Regeneration Theory," *B.S.T. Journ.* II, p. 126. (1932).

<sup>2</sup>Nyquist's criterion of stability is correctly stated: "Plot plus and minus the imaginary part of the fed-back vector against the real part for all frequencies from zero to infinity, with the feedback line open-circuited at the input, and for an input of  $(1 + j0)$ . If the resultant curve does not enclose the point  $(1 + j0)$  the amplifier is stable." The simplified version given in the text above is correct in most practical cases. It does not, however, cover the case (for example) of the "nyquist" or "conditional" amplifier in which a reduction of gain leads to instability.

ABAC No. 18  
[Third Series]

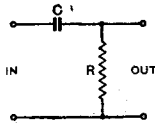

TIME CONSTANT OF RC (MEG OHMS x MICROFARADS)

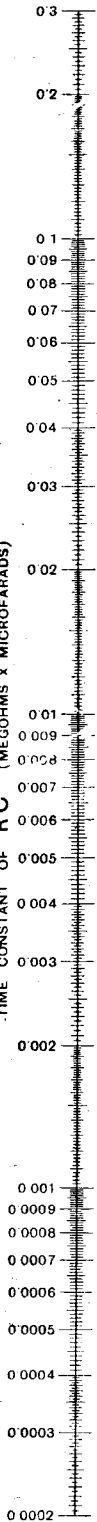

FREQUENCY IN CYCLES PER SECOND



TRANSMISSION FACTOR

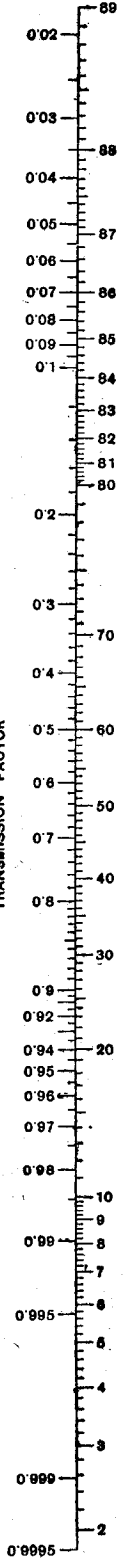

PHASE SHIFT IN DEGREES

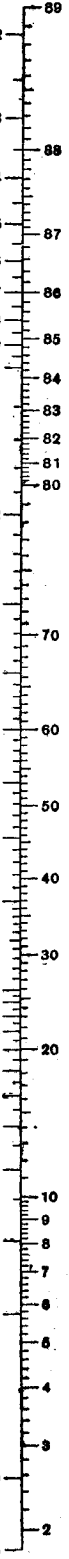

TRANSMISSION AND PHASE SHIFT OF RC COUPLINGS

Wireless World  
COPYRIGHT



# UNBIASED

## Horrors of Peace

THE British Interplanetary Society has always commanded my greatest respect because its work, like my own, lies so far above the heads of ordinary men. It is hardly to be expected, however, that the members of the Society would have available to them the same sources of under-the-counter information as myself and I do not think that they can be aware of the advanced stage which has been reached for the post-war commercial exploitation of the radio potentialities of V2, to certain aspects of which Arthur C. Clarke, a member of the Society, draws our attention in a letter published in the February issue of *Wireless World*.

Mr. Clarke tells us that by greatly increasing the speed of V2, we could have, circling round the earth for ever, an artificial satellite. After suggesting that this will be accomplished within a decade or so, he goes on to state that in perhaps half a century we shall be able to have in the sky three V2 contraptions which would, relative to the Earth, be securely anchored in one position, and that these could be used as microwave relay stations to provide television and sound coverage for the whole of the Earth's surface.



"Under-the-counter information."

This information is, as far as it goes, thoroughly sound and reliable, but what Mr. Clarke does not tell us in his letter is that certain business interests which in pre-war days used to give, from well-known con-

By  
**FREE  
GRID**

●  
Cimex Radionis.

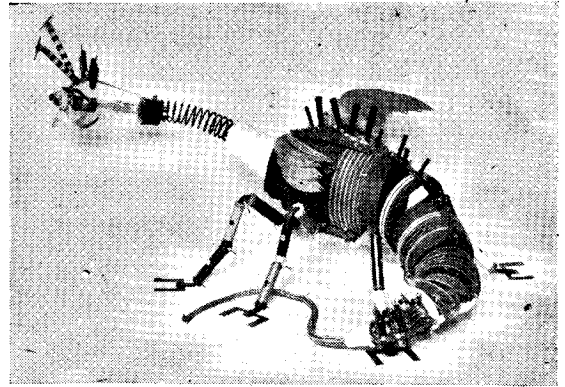

tinental stations, indelicate details of our internal anatomy in order to warn us of the awful fate awaiting us if we did not purchase their wretched pills and potions, are preparing to take the field on a far grander scale. They are, in fact, planning to launch into the firmament a veritable flock of these devilish devices, each completely equipped with transmitter and an almost endless supply of recorded programmes and advertising propaganda, the latter being made possible by the enormous strides made in microfilm technique.

The danger is a very real one, since once these things are in the air they would stay there for ever, the only limitations of their life being ordinary wear and tear of the moving mechanical parts of the reproducing apparatus; this, of course, can be reduced to a negligible amount by modern technique. All needed electrical power can, as Mr. Clarke rightly points out, be derived indirectly from solar energy.

## Freud Had a Word For It

WE frequently hear it said that no matter how great and famous or how erudite and learned a man is, he will always be found to possess human weaknesses like ourselves. If the history books are to be believed, even Judge Jeffreys, who earned undying fame at what the B.B.C. would no doubt call the Sanguinary Assize, had a tender spot in his heart for cats; so much so that on one occasion when he had sentenced a man to be hanged, drawn and quartered, he mercifully changed the quartering part of the sentence to halving on hearing that the prisoner was a fellow felophile.

In spite of all this I cannot say that I had ever experienced any personal proof of this human trait in the lives of the great until fairly

recently when I went by invitation to the works of one of the few wireless companies (maybe the only company) which can claim to have been actively engaged in business during the reign of Queen Victoria. Actually, I believe, they fitted the Royal yacht with a wireless installation in 1898. Of course, in those far-off days wireless was merely a matter of telegraphy, and it was not, therefore, one of the B.B.C.'s programmes which drew the famous "We are not amused" from the lips of the Queen.

As I passed through the famous portals and tripped clumsily over a discarded "maggie" in the vestibule, nostalgic memories of the "naughty 'nineties" came back to my mind. When I was ushered into the presence of the great by an attendant fairy who took my card, I half expected to hear the irritating tapping of the decoherer and to see long-forgotten faces in the room into which I was shown. I had, at any rate, expected to be confronted by grave and reverend seigneurs bending with unhuman seriousness and cold and calculating scientific mien over the modern counter-parts of the 10-inch coil and coherer.

As I entered the room my expectations were, with one exception realised. The grave and reverend seigneurs were certainly there, and they were, in truth, bending with all seriousness over an object on the table which I at once took to be the *demier cri* in the world of wireless wizardry. I was astounded, therefore, when I saw the object to which one of them was just putting the finishing touches. I promptly asked and received permission to photograph it and reproduce the result here for your benefit. I can only suppose that it is one more piece of evidence of that peculiar trait in the character of the great and learned to which I have already referred. Freud would, no doubt, have a word for it; so have I, but the Editor won't let me use it.

# "IT CAN NOW BE REVEALED . . ."

## Some Achievements of the British Radio Industry

Thanks to a relaxation of censorship rules, it is now possible to write more freely on some of the outstanding contributions of wireless during the war. Although the full story cannot yet be told, we are, for example, able to publish articles on the principles and origins of radiolocation. Last month, at the inaugural luncheon of the Radio Industry Council, F. B. Duncan, the chairman, referred to a number of topics that have hitherto been banned. Relevant extracts from Mr. Duncan's speech are printed below.

IN actual use in the war, the story of the results we [the British radio industry] helped to make possible begins with the Battle of Britain. Radiolocation gear enabled men on the ground to detect and plot the course of enemy aircraft from miles away. The enemy suddenly realised that the British Nation was one scientific jump ahead of him.

From this first result our scientists, designers and technicians have strained every nerve to invent and perfect new gear. Every anti-aircraft gun-site and every searchlight in this country was equipped with special type radiolocation which reduced the human error in sighting. New findings enables British naval vessels to be the first in which dead-accurate gun-laying was assisted by radio beam. In 1941 an Italian fleet off Matapan was blasted from the sea by the guns of British cruisers and destroyers aided by radiolocation in a pitch darkness. Last year the *Scharnhorst*, the proud boast of Germany, was sunk at an incredible range of many miles by battleship gun-fire dead on the target, with the help of still more advanced radiolocation gear.

By the second year of war night fighters were led by a ground control to enemy aircraft. The destruction of the night bomber was made possible largely due to this and the uncanny searchlight accuracy. As our attacks grew by further development bomber aircraft were directed unerringly to their targets.

D-Day saw the most pregnant development of all when new and special types of radiolocation enabled our airborne and parachute troops to be accurately concen-

trated by radio on minute landing areas in darkness. No other means could have kept in contact and prevented the dispersal of forces so large as those involved.

To-day, pin-point aerial bombardment is assured by the recently disclosed "black box" which gives the bomber pilot an ever-changing picture of the earthly scene below him, so that neither darkness, nor cloud, nor fog obscures the target from him.

Probably the best single contribution from British engineers will ultimately prove to be an item to which we cannot now give a name. It is a vacuum device, something infinitely more than a valve, of such delicacy and complexity that only the most skilful hands can make it. This is the heart of many of the most advanced types of radiolocation gear, permitting effective operation on very high frequencies.

After the war it will be directly applied to automatic and infallible anti-collision devices, which will ensure the safety of ships and aircraft all over the world's traffic routes.

I could continue to tell you of the many applications of radio gear to tanks, ships, aircraft, which amount to stupendous totals, some of which are clearly indicated in the recently published White Paper, but it would still be impossible for me to give you a proper picture of the complicated technical and engineering work that has been done in our valve, component and equipment factories, but when it is fully told it will stand as a lasting monument to the British radio industry . . . its technicians, and its work-people. . .

# GALPINS

## ELECTRICAL STORES

"FAIRVIEW,"  
LONDON ROAD, WROTHAM,  
KENT.

TERMS: Cash with order. No C.O.D.  
All prices include carriage or postage.

**ELECTRIC LIGHT CHECK METERS**, first-class condition, electrically guaranteed, for A.C. mains, 200/250 volts 50 cy. 1 phase 5 amp. load, 11/- each.

**SOLDID BRASS LAMPS** (wing type), one-hole mounting, fitted double contact, S.B.C. holder, and 12 volt 16 watt bulb. 4/-.

**TUNGSTEN CONTACTS**,  $\frac{3}{8}$  in. dia., a pair mounted on spring blades, also two high quality pure silver contacts,  $\frac{3}{8}$  in. dia., also on spring blades, fit for heavy duty, new and unused. There is enough base to remove for other work. Set of four contacts, 4/-.

**ROTARY CONVERTER**, input 40 volts D.C. output 75v., 75 m/A, A.C., also would make good 50v. motor or would generate. 22.

**AUTO TRANSFORMERS**. Step up or down tapped 0-110-200-220-240; 1,000 watts. 25.

**POWER TRANSFORMER**, 4kW, double wound, 400 volts and 220 volts to 110 volts, 50 cycle, single phase. Price 220.

**AUTO TRANSFORMER**, step up or step down 500 watts, tapped 0-110-200-220-240 volts. 23 10s.

$\frac{1}{2}$  WATT WIRE END RESISTANCES, new and unused, price per doz., 5/-, our assortment.

**MOVING COIL AMPMETER** by famous maker, 2in. dia., flush mounting, reading 0-10 amps., F.S.D., 20 M/A, price 27/6.

**AMPLIFIER COMPONENTS** from dismantled American 10 and 20 watt amplifiers, all metal cases and compound filled.

**INPUT TRANSFORMERS**, ratio 12 to 1, centre tapped, price 15/-.

**P.P. OUTPUT TRANSFORMER**, ratio 6.2 to 1, centre tapped, price 10/-.

**POWER TRANSFORMER**, pri. 95/100 v., sec. 260-0-260 at 80 M/A, also 5 v. at 3A, price 12/6.

**METAL RECTIFIERS**, size 14 x 3 $\frac{1}{2}$  x 3 $\frac{1}{2}$  in., output 50v., 1 amp., 35/-; another 5 $\frac{1}{2}$  x 2in., output 100v.-250 M/A, 17/6; another 200v.-50 M/A, 10/-.

**CABINET LOUDSPEAKER**, for extension only, 5 watt output, 8in. dia. cone, high quality, size of cabinet 16 x 14 x 8 $\frac{1}{2}$  in. x  $\frac{1}{2}$  thick, cabinet slightly marked at top, price 23.

**SMALL M.L. ROTARY CONVERTER**, in cast alli. case, size 14 x 4 $\frac{1}{2}$  x 4 $\frac{1}{2}$  in., permanent magnet fields, converters need attention, not guaranteed, 30/-.

**POWER TRANSFORMER**, suitable for arc welding, input 230v., 50 cycle, 1 PH, output 50 volts at 200 amps., price 217; ditto, output 150 amps, 215; ditto, output 100 amps, 212.

**METAL RECTIFIER**, output 6v.-1 amp., 12/6; ditto, output 500v.-120 m/A, 30/-; ditto, output 200v.-100 M/A, 17/6.

**TRANSFORMER** for rewinding only, approx. 2kW, weight complete with clamps, 45 lbs., price 30/-.

**BLOCK CONDENSERS**, 4 MF, 300v., AC working, 6/-.

MOVING COIL AND M.I. METERS.

FOR FULL DETAILS OF ABOVE AND OTHER

GOODS, SEND FOR LIST, 2½d.

# WORLD OF WIRELESS

## COMMONWEALTH BROADCASTING

MANY problems on both the technical and the programme side of Commonwealth broadcasting can best be solved by round-table discussion, and when the European war ends the character of the broadcasting interchanges between countries of the British Commonwealth will entirely change. It is to discuss these common problems and to explore the field of post-war co-operation that representatives of the Dominion broadcasting organisations are now meeting in London. The delegates will also exchange information, experience and ideas on many professional matters such as technical developments, programme technique, controversial broadcasting and school broadcasting.

During the Conference, which began on February 15th and closes on March 9th, the delegates will visit many B.B.C. establishments throughout the country.

Among those attending the Conference are: Howard B. Chase, chairman, and E. L. Bushnell, Canadian Broadcasting Corporation; Col. C. J. A. Moses, general manager, Australian Broadcasting Commission; Prof. J. Shelley, director, and J. R. Smith, chief engineer, New Zealand National Broadcasting Service; Major R. S. Caprara, director, South African Broadcasting Corporation; N. Filmer, branch manager, and H. Collett, divisional engineer, Transvaal Division of S.A.B.C.; Prof. A. S. Bokhari, director general, C. W. Goyder, chief engineer, and S. Gopalan, development and planning officer, All-India Radio.

## "NO NATIONAL BOUNDARIES"

THE chief of the Telecommunications Division of the U.S. Department of State, Francis Colt de Wolf, addressing the 33rd annual meeting of the American Institute of Radio Engineers, stated that for the past two years they had been working on plans for post-war telecommunications. He said that in formulating their plans they had in mind a modernisation of the existing international telecommunication bodies, bringing them more in line with the necessities of present-day radio, particularly in the field of radio interference and radio regulation.

He stressed the need for deciding whether they were "prepared to surrender a certain modicum of sovereignty to insure a more efficient control of radio, for radio knows no national boundaries."

Mr. de Wolf announced that the

third Inter-American Radio Conference would be held in Rio de Janeiro in June.

## APPOINTMENTS BUREAU

AS a result of meetings between representatives of the Institutions of Civil, Mechanical and Electrical Engineers, it has been decided to form a Professional Engineers' Appointments Bureau. The complementary objects of the Bureau are to provide employers with a source from which they can obtain the services of qualified civil, mechanical and electrical engineers and to afford members of the three institutions a means of introduction to prospective employers.

The Bureau will be administered by a Board consisting of the president, secretary and three members of each of the institutions. It will not be run for profit, and will be operated apart from the three institutions.

It is anticipated that the Bureau will ultimately become self-supporting, but an appeal has been made for donations to start a fund to carry it through the formative years.



**FARADAY MEDALLIST.** Dr. C. Paterson, O.B.E., F.R.S., has been awarded the Faraday Medal by the Institution of Electrical Engineers for conspicuous services rendered by him in the advancement of electrical science, particularly in the field of electrical research. Dr. Paterson, who has been director of the G.E.C. Research Laboratories since its inception, is a past president of the I.E.E., and was elected a Fellow of the Royal Society in 1942.

## RADIO OFFICERS

FOLLOWING the recent question in the House of Commons on the surplus of marine radio officers, enquiry was made of the Radio Officers' Union regarding the present situation. It was learned that there are enough men in the Merchant Navy Reserve Pool to meet present requirements, and, moreover, that the intake of radio officers without previous seafaring experience has practically ceased.

In reply to the question in the House, the Postmaster-General stated that the wireless telegraphy schools were advised last June that the present situation was foreseen. He also pointed out that the granting of the P.M.G.'s certificate carries no guarantee of employment.

## CANADIAN SHORT WAVES

FURTHER details are now available of the test transmissions from Canada's new short-wave station at Sackville, New Brunswick. Transmissions on 15.22 and 17.82 Mc/s are radiated on weekdays from 1045-1315 and on Sundays from 1130-1715 GMT.

Reception reports are still required and should be sent to A. E. Powley (not Porter as stated last month), Canadian Broadcasting Corporation, 32, Great Castle Street, London, W.1.

The official opening date of the station has been postponed until March 10th.

## ATHENS RADIO

WITH the reopening of the Athens wireless telegraph station on January 29th for Press traffic, another chapter in the short history of this station opens.

Cable and Wireless established direct wireless communication between London and Athens in 1940. Short-wave listeners will remember that soon after the Athens station was opened it was adapted for telephony and used for a short period each evening to transmit news bulletins in foreign languages. From the occupation of Greece in April, 1941, until its liberation from the German Forces in October last year the station was closed.

During the internal strife in December the station, which is at Pallini, some eight miles from the capital, was cut off from Athens except for an underground cable. The power supply was cut, but the transmitter was operated from an emergency source, and supplies were dropped to the besieged staff and garrison by parachute.

On December 30th the E.L.A.S.



attacked the station and simultaneously cut the underground cable. Although under fire and with one of the engineers wounded, one transmitter was maintained so that a message could be sent to the Athens H.Q. via London giving news of the attack. The staff was later ordered to immobilise the station and prepare to leave. In an hour thousands of pounds' worth of valves was destroyed.

The station was occupied by E.L.A.S. for only eight days.

**SUBSCRIPTION TELEVISION**

THE possibilities of introducing a subscription television service is discussed by the president of the Scophony Corporation of America.

The Scophony programme would be confined to subscribers by a system of scrambling.

Subscribers would receive a celluloid or paper "pattern" which could be inserted in the unscrambling device. The "pattern" transmitted by Scophony stations would be changed periodically.

**U.S. WAR SURPLUS**

THE recent correspondence appearing in *Wireless World* on the disposal of war surplus equipment raises interesting comparisons with American schemes.

Plans have been made whereby manufacturers act as "disposal agents" for surplus Government apparatus. This presumably applies to unused apparatus only as the plan provides for the manufacturer-agent to sell his own products for the Government-appointed Defence Supplies Corporation on a "commission basis."

**WHAT THEY SAY**

**RADAR: A WINNER.**—In 1940 it became clear that the country most advanced in radar would win the war. This country up to the laboratory stage, was the most advanced in the world. But it was not much good having a great laboratory unless you had the craftsmen.—*Mr. Bevin, Minister of Labour, recalling response of radio men to operate Radar.*

**COMPARISONS ARE ODIUS.**—In view of the larger number of pre-war sets purchased in England, that country may resume television on pre-war standards, but the British may emerge with a television system which might set the pace for the rest of the world, except for the single American advance of colour. . . . The British . . . have not produced a practical full-colour system. . . . Thus the United States seems to be in the enviable position of having world leadership in television at its finger-tips.—*Paul W. Kesten, C.B.S. Executive Vice-President, speaking on his recent visit to England.*

**LARGE-SCREEN TELEVISION.**—It will be our policy, as soon as circumstances permit, to develop a television unit displaying a screen about 3ft. by 2ft. and introducing colour, with the further aim of producing, as before the war, a large unit suitable for public entertainment, but with the addition of the use of colour. We do not for a moment suggest that such units can be brought to the point of satisfactory commercial exploitation without a considerable period of development.—*Sir Maurice Bonham Carter at the Annual General Meeting of Scophony Ltd.*

**HIGH POTENTIAL.**—The threat to drive [U.S.] television off its present familiar channels into the UHF and to delay video by five years or more, is actually a threat to delay employment—to hold up jobs for 600,000 people, post-war, at a time when jobs will be so vitally needed. . . . Television, if continued on its present channels, has a potential employment-creating value at least equal, if not double, that of present radio-broadcasting.—*"Electronic Industries," New York.*

**TECHNICAL TACTICS.**— Formal science, by theory and experiment, opens a bridgehead on the industrial front; the bridgehead is enlarged by the oriented empiricism of good technical practice; and the gains are consolidated by further applications of formal science.—*Sir Robert Watson Watt, discussing the interplay of formal science and practical radio development, at the British Association Conference on the "Place of Science in Industry."*

**U.S. CIVILIAN SETS**

IT is announced by the Radio and Radar Division of the American War Production Board that "there is no possibility in the near future of making any new civilian sets, in view of military demands." Moreover, replacement components and valves are being manufactured in a limited quantity—sufficient to keep "an average of one set in operation in each radio-equipped home"!

**PERSONALITIES**

**Dr. William L. Everitt** has been elected president of the American Institution of Radio Engineers. He was recently appointed head of the department of electrical engineering at the University of Illinois, but at present is on war work as Chief of the Operational Research Branch, Office of the Chief Signal Officer, U.S. Army. His research work has been mainly concerned with high-power radio amplifiers and impedance-matching circuits. He is the author of "Fundamentals of Radio."

**Dr. Peter C. Goldmark** has been appointed Director of a new depart-

**CRONAME**  
RADIO COMPONENTS



**MILITARY** demands on the electronics industry require large quantities of material made to precision standards never before approached by quantity production methods. Crowe has had signal success in solving problems of rapid production of precise electronics control mechanisms. This experienced ability will be an important factor in the post-war programmes of many firms.

Exclusively Represented in Great Britain by  
**FRANK HEAVER LTD.**  
Kingsley Road, Bideford, N. Devon.

**CRONAME INCORPORATED**  
(formerly Crowe Name Plate Mfg. Co.)  
CHICAGO, ILL. U.S.A.

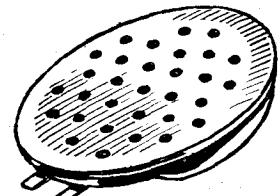

H.A.5 DEAF-AID  
CRYSTAL MICROPHONE

**A**STATIC will be ready to serve you again with high quality piezo-electric devices when the 'All-Clear' of Victory sounds. Astatic deaf-aid microphones can be supplied only if Import Permits are established. Model H.A.5 illustrated is used as standard by America's leading hearing-aid instrument makers.



THE ASTATIC CORPORATION  
CONNEAUT, OHIO, U.S.A.  
and  
TORONTO, CANADA.

Exclusively Represented by  
**Frank Heaver Ltd.** Kingsley Road, Bideford, N. Devon



**World of Wireless—**

ment of the Columbia Broadcasting System, that of Engineering and Research.

**L. A. Hooke**, who has succeeded Sir Ernest Fisk as Managing Director of Amalgamated Wireless (Australasia), Sydney, has been General Manager since 1936 and associated with the company since its incorporation in 1913.

**David Sarnoff**, President of R.C.A., who was recently awarded the Legion of Merit, has been promoted from the rank of Colonel to Brigadier General.

**Paul A. Porter** has been appointed chairman of the U.S. Federal Communications Commission in succession to James L. Fly, who has retired.

**N. K. Bunn** (Works Manager) and **J. L. Harvey** (Production Manager) have been appointed Joint General Works Managers of British Insulated Cables. **W. J. Clements** is appointed Works Manager.

**C. A. Edgell**, whose appointment as Sales Manager of British Mechanical Productions (Clix radio components) is announced, has for nearly three years been Administrative Manager of the Company's factories concerned mainly with the production of radio components.

**OBITUARY**

It is with regret we record the following deaths.

**K. L. Wood**, who joined the Eastern Telegraph Co. (later taken over by Cable and Wireless) in 1899, retiring from the position of Engineer-in-Chief in 1939, died on Feb. 4th, aged 61.

**F. R. S. Balfour**, who died recently, aged 71, was director of many companies, including Cable and Wireless, Marconi International Marine Communication Co., and Marconi Sounding Device Co.

**N. S. Holland** died on January 22nd. He resigned from his position as director of A. C. Cossor last year owing to ill health.

**Dr. Walter Weber**, chief engineer of the technical department of the German Broadcasting Company, has died recently. He was responsible for many improvements in German transmitting apparatus and carried out important research on the interference method of measuring non-linear distortion, and the high-frequency magnetophone—an important advance in the technique of magnetic recording.

**IN BRIEF**

**FM Growth.**—When last we reported the number of applications for FM stations awaiting decision by the U.S. Federal Communications Commission, which was in July, the figure was 190. It has now increased to over 300.

**Anglo-U.S. Co-operation.**—The President of the Radio Executives' Club of New York recently presented on behalf of its members a scroll to the B.B.C. "in appreciation of its unstinting co-operation with American broadcasters, networks and independent stations to make complete the coverage of the war, and for inspiring radio throughout the world to become a powerful voice which will declare ever loudly for all

the people their desire for everlasting peace."

**B.B.C. Monitoring Service** recently produced the 2,000th issue of *Digest of World Broadcasts*. This *Digest* is Britain's largest daily publication, translating into English the broadcasts received in 32 different languages. A million words a day are heard from stations all over the world; by eliminating repeat broadcasts and selecting the required material this is reduced to 300,000 words. Thus is cut and edited down to some 100,000 words, comprised in the *Digest*, which is produced on seven days a week.

**Canadian R.T.P.B.**—Canada, like its neighbour the U.S., has appointed a Radio Technical Planning Board. Panels, or committees, have been appointed to study specific aspects of radio, such as FM, television, international SW, radiotherapy, industrial electronics and standard broadcasting, from whose reports recommendations will be made to the Dominion Government for international consideration.

**Phototelegraphy.**—During the three months ended in November more than 340 photographs were sent by radio from London to Buenos Aires. Cable and Wireless states that reception of 86 per cent. of the transmissions was reported "good."

**Leicester Radio Society** has been successfully restarted and at their next meeting, on March 6th, A. Folwell, the secretary, will give a demonstrated talk on cathode-ray tubes. A further meeting of the society is to be held on March 20th, when S. May will lecture on "The Spectrometer and its Applications." Both meetings commence at 7.30 at the United Baptist Chapel, Charles Street, Leicester.

**M.M. for Radio Operator.**—The Military Medal has been awarded to L.A./C. Ranger, R.A.F.V.R., for maintaining communications between the R.A.F. headquarters in the Epirus area of Greece and Cairo. Eighteen months ago he landed in Greece by parachute and was placed in charge of a radio set. On two occasions during the fighting he dismantled the set under fire and played a leading part in saving the equipment and preventing casualties.

**15,000 tons of waste paper** are urgently needed for use in the manufacture of wall board to repair houses damaged by enemy action.

**MEETINGS****Institution of Electrical Engineers**

*Radio Section.*—"Frequency Modulation," by K. R. Sturley, Ph.D., B.Sc., March 7th.

"Colour Television," discussion to be opened by L. C. Jesty, B.Sc., March 13th.

"Apprenticeship and Trainee Systems in the Radio Industry," discussion to be opened by J. Greig, M.Sc., Ph.D., March 20th.

All these meetings will be held at 5.30 at the I.E.E., Savoy Place, Victoria Embankment, London, W.C.2.

*Cambridge Radio Group.*—"Multipath Interference in Television Transmission," by D. I. Lawson, M.Sc., March 13th, at 6 o'clock at the Technical College, Collier Road, Cambridge.

"The Design and Manufacture of Radio Valves," by G. Liebmann,

Ph.D., March 27th, at 7 o'clock at the University Engineering Department, Trumpington Street, Cambridge.

*South Midland Radio Group.*—"An Elementary Description of Some Molecular Concepts of the Structure of Dielectrics," by E. B. Moullin, Sc.D., at 6 o'clock at the James Watt Memorial Institute, Birmingham, on February 26th.

*London Students' Section.*—"Mercury Arc and Mercury Vapour Rectifiers in Transmitters," by T. M. Ellison, March 5th, at 7 p.m. at the I.E.E.

**British Institution of Radio Engineers**  
*London Section.*—"Dielectric Heating by the Radio Frequency Method," by L. Grinstead, at 6 o'clock at the Institution of Structural Engineers, 11, Upper Belgrave Street, London, S.W.1, on February 28th.

*Midlands Section.*—"Magnetic Dust Cores," by E. R. Friedlaender, at 6 o'clock at the University of Birmingham (Latin Theatre), Edmund Street, Birmingham, on February 28th.

*North-Eastern Section.*—"Proposals for Television and Broadcasting Transmission Systems," by W. A. Beatty, at 6 o'clock in Neville Hall, Newcastle-on-Tyne, on March 14th.

**Royal Society of Arts**

"The Making of a Gramophone Record," by H. W. Bowen, on March 21st, at the Royal Society of Arts, John Adam Street, Adelphi, London, W.C.2, at 1.45.

**Royal Institution**

"Some Aspects of Pre-War and Post-War Television," by H. L. Kirke, on March 2nd.

"Is Human Speech Good Enough," by Sir Richard Paget, on March 23rd.

Both meetings commence at 5 o'clock at the Royal Institution, 21, Albemarle Street, London, W.1.

**Institution of Electronics**

*North-West Branch.*—"Pulse Generation," by Dr. F. J. G. van den Bosch, on March 23rd, at 6.30 at the Reynolds Hall, College of Technology, Manchester.

**Institute of Physics**

*Electronics Group.*—"Electron Diffraction," by G. I. Finch, F.R.S., March 6th, at 5.30, in the small Physics Theatre, Imperial College of Science and Technology, Prince Consort Road, London, S.W.7.

**Television Society**

Annual General Meeting, followed by a discussion on "Some Social Aspects of Television," opened by Capt. C. H. Cazaley, R.E.M.E., on March 27th, at 5.30 at the I.E.E., Savoy Place, Victoria Embankment, London, W.C.2.

**City and Guilds Radio Society**

"Harmonic Analysis at Very-High Frequencies," by D. M. Tombs, M.Sc., on March 2nd.

"The Transmission of Television Signals over Ordinary Non-loaded Telephone Pairs," by A. R. A. Rendall, Ph.D., on March 9th.

"Some Problems in Instrument Design," by F. E. J. Ockenden, on March 16th.

All these meetings will commence at 5.15 at the City and Guilds College, Exhibition Road, London, S.W.7.

## Letters to the Editor

### Technical Training Criticisms • Books: Good and Bad • What is "Static"?

#### "Radio Engineering Education"

IN the February issue of your paper appeared an article on "Radio Engineering Education," by Thomas Roddam, who makes an outrageous criticism of the polytechnics, which he regards as bad and sterile. He remarks that a large proportion of recruits to the industry are coming from the polytechnics and from Hankey courses in the Universities.

Mr. Roddam's knowledge of the educational facilities in this country is lamentable, as there happen to be polytechnics only in the London area, and I do not believe that he really meant to criticise only those few institutions in the London area which bear the name of "polytechnic." In fact, his ignorance is so great that he is unaware that the provincial university which apparently meets his requirements was in all probability previously an institution exactly comparable with a polytechnic. Furthermore, Mr. Roddam's statement that a large proportion of to-day's recruits to radio are coming from the polytechnics obviously betrays his abysmal ignorance even of the radio industry, as it is quite well known that the large proportion of the people entering the industry have had no training whatever.

T. J. DRAKELEY.

Association of Principals of  
London Polytechnics.

I AM very pleased to find the problems of education being thrashed out in the Press and agree by and large with your contributor Thomas Roddam. I think he is a little impatient, however, with the full- and part-time staffs of polytechnics and technical colleges who, despite their lack of contact with phenomenally rapid wartime developments and lack of experimental and more particularly measuring apparatus, were able to train tinkers and tailors as wireless and radio mechanics.

A suitable textbook is notice-

ably lacking, and as radio is entering many new fields I feel that a comprehensive survey could best be made by inviting contributions from accepted authorities in Government or industrial research laboratories to an outline drawn up by themselves and representatives of the teaching profession. The whole should be edited as regards technical and mathematical standard by someone with teaching experience.

J. W. BAYLISS.

North Cheam, Surrey.

WITH respect to the training of future radio engineers, I say at once that I entirely agree with the views of Thomas Roddam, but I cannot agree with your Editorial view that the so-called "academic" education of engineers should be mixed up with training in industry. From my own experience and that of teaching electrical communication to students from first-year National Certificate to higher degrees in electrical communication, I am quite convinced that the best years for acquiring sound fundamental knowledge are between the ages of 15 and 21, and that none of this time should be unnecessarily wasted in picking up odd bits of information in a works. After the age of 21 it becomes increasingly difficult to appreciate fundamental knowledge. In works there is a general tendency to disregard the finer criticism of fundamental issues when a general line of least resistance of getting on with the job at all costs prevails.

These two points of view cannot be reconciled and if, at a much later age, you wish to have people in industry of high critical faculties, they should be left in a continuity of learning as long as possible. Short vacation courses in works can make better use of holiday times, no doubt, but it must always be remembered that students of Universities go into many avenues apart from industry, and to insist that all such



#### THE "FLUXITE QUINS" AT WORK

"When we're down off this roof—I'll be glad, My fingers are frozen, bedad!"

Yelled EE "Hey! Hold tight!

We'll need that FLUXITE,

We're soldering—not ski-ing, m'lad!"

See that FLUXITE is always by you — in the house — garage — workshop — wherever speedy soldering is needed. Used for over 30 years in Government works and by leading engineers and manufacturers. Of all Iron-mongers—in tins, 8d., 1/4 & 2/8.

Ask to see the FLUXITE SMALL-SPACE SOLDERING SET—compact but substantial—complete with full instructions, 7/6.

TO CYCLISTS! Your wheels will NOT keep round and true unless the spokes are tied with fine wire at the crossings AND SOLDERED. This makes a much stronger wheel. It's simple—with FLUXITE—but IMPORTANT.

The FLUXITE GUN puts FLUXITE where you want it by a simple pressure. Price 1/6, or filled, 2/6



ALL MECHANICS WILL HAVE

# FLUXITE

IT SIMPLIFIES ALL SOLDERING

Write for Book on the ART OF "SOFT" SOLDERING and for Leaflets on CASE-HARDENING STEEL and TEMPERING TOOLS with FLUXITE. Price 1d. each.

FLUXITE LTD.

(Dept. W.W.), Bermondsey Street, S.E.1

**Letters to the Editor—**

students, many of them destined to become research workers, should spend valuable years in works is a misleading policy.

L. E. C. HUGHES.

London, N.W.8.

**"Pity the Poor Student"**

I AGREE with Sqn. Ldr. A. M. Hardie that your reviewer "T. R." is to be congratulated for his courageous stand regarding the bad technical books which are now being published.

There is no short cut to scientific knowledge, and least of all to mathematical knowledge. Instead of wasting time and money in publishing new books, would it not be possible to reprint some of the old mathematical and scientific books which are far better than the modern ones.

I have in mind the books of Professor Augustus de Morgan, the greatest teacher of mathematics which this country has produced. It was left to the Open Court Publishing Company, of Chicago, to reprint, in 1898, his books on "The Study and Difficulties of Mathematics" and "Elementary Illustrations of the Calculus," which should be in the hands of every teacher and student of mathematics.

I suggest that some enterprising firm reissue his two small books on Algebra and Trigonometry. There are no better and clearer books in existence, although they were written some 100 years ago. As Professor de Morgan pointed out, mathematics, when taught as an art, has no value. To-day mathematics as a science is not taught at all, and least of all in the modern text-books.

LIONEL CALISCH.

London, S.W.5.

**AGC Circuit**

IN superheterodynes demodulation is sometimes achieved by circuits which do not lend themselves easily to the production of an automatic gain control voltage.

With such gear it has been found convenient to take off part of the IF, say, after the first IF amplifier, apply it to the triode portion of a double-diode-triode for magnification and subsequent detection in the diode portion of the same valve.

No trouble has been experienced with an inductive anode load, as the heavy damping of the diode across it prevented the triode from falling into oscillation. At the same time the anode-grid capacity was regenerative enough to give the valve a high input impedance, thus introducing very little damping into the attached associated circuit.

The valve is run on a self-biased cathode of 2-3 volts, this being the delay for the AGC diode. Medium- $\mu$ u and medium high- $\mu$ u valves have been used with advantage. The general picture of a set fitted with the new gadget is given in the diagram.

As was to be expected the

prevent racketeering, and the entry (as after the last war) of new speculators who merely buy and sell surplus material as such, and contribute nothing to the industry generally.

There are still left in the Trade a number of the old-time radio component dealers, who sincerely tried to give real service, both in war and peace. I suggest that these people, so many of them as are left, formed the real backbone of the radio industry in the early days, and went to great lengths to assist the enthusiast in every way, to foster his enthusiasm, and to make the material available as freely and as cheaply as possible.

R. H.

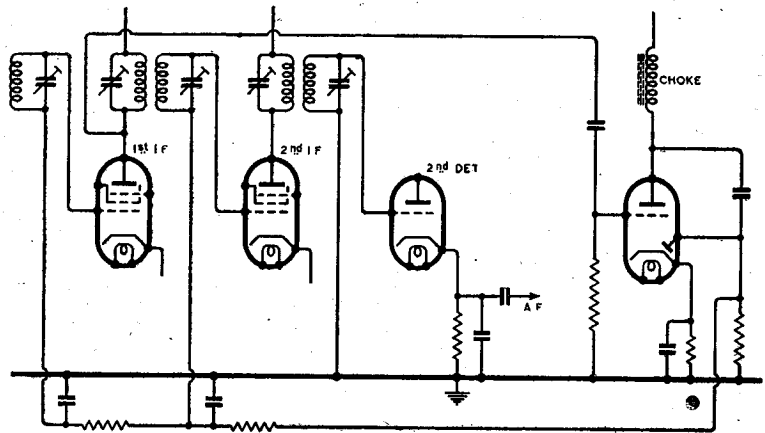

Circuit including AGC arrangement described by K. E. Marcus.

arrangement produced an "over control," as on strong signals the AGC voltage was far in excess of the AF voltage across the demodulator load, whilst on weak signals the AF output exceeded the control voltage. 40db fading gave no appreciable difference in sound intensity, apart from the well known "approaching" of the background noise.

K. E. MARCUS.

Uxbridge, Middx.

**War Surplus Disposal**

I HAVE read with interest the discussion in your columns about the disposal of war surplus equipment, and I should like to give as my view that it would be fairer in every way if the Government were to adhere to the original promise, expressed some months ago in the daily Press, to sell this equipment through the normal Trade channels, and thus

**Electric Lamp Failures**

BY a coincidence I had exactly the same experience yesterday as your contributor "K. G. B." (see p. 49 of the February *Wireless World*). The noise emitted was a fairly high-pitched hum, but the interference with a small receiver in the same room was sufficient to drown the local broadcast almost to extinction. The interference disappeared with the substitution of the lamp.

C. ATHERTON.

Manchester.

[This refers to the type of lamp failure where the glow from a broken filament is maintained by thermionic emission. In a footnote to "K. G. B.'s" contribution last month we expressed doubt as to whether serious interference with wireless reception could be caused by this kind of lamp fault. From the above letter and many others we have received it now



seems to be definitely established that such failures are in fact responsible for strong interference. —Ed.]

**Justifying "Static"**

IN the November, 1944, number of *Wireless World* T. W. Bennington rightly deplores the use of the word "static" to describe radio noise produced by lightning flashes. But there is a proper and clearly defined use for "static" as distinct from "atmospherics." If we adopted a lightning conductor as a shunt-fed aerial, when local thunder-clouds were present there would be a soft corona discharge from the conductor, and it would be excited in its normal nodes. A characteristic rushing or hissing sound would be received, and this noise would properly be called "static." Any aerial having a DC path to earth may behave in this way, although

the sharp point of a lightning conductor will increase the effect. An unearthed aerial, in the presence of high electrostatic fields, will charge up, and may reach a potential sufficient to "corona" to earth, if the condenser is sufficiently good to prevent leakage.

Another form of static may be produced in rubber-tired vehicles which can charge to sparking potentials as a result of the suction of the tyres on the road. This effect is well known in hospitals, and I believe that patients under anaesthetic have been known to explode when a spark has detonated the air-ether mixture in their lungs. The trailing chains behind petrol lorries are a familiar sight, and provide an earth leak for those charges.

I would urge that B.S.I. should canonise this use of "static," which in its common use is a redundant and confusing term.

THOMAS RODDAM.

**RANDOM RADIATIONS**

By "DIALLIST"

**Robust Radiolocation Gear**

TO me one of the greatest triumphs of our "secret weapon," radiolocation, is that these delicate and highly complicated instruments were so designed and made as to be able to stand up to the rough treatment of war. I frankly admit that when I first heard that it was intended to install them on A.A. gun-sights I thought that they would never withstand either the vagaries of the weather or the heavy vibration due to gunfire at close quarters. But they did, even from the first. It would be difficult to imagine conditions more trying to wireless gear of any kind than those which prevailed during the thaws following the cold spells of the early war years. With the melting of the snow the ground became a quagmire and the foggy air was so damp that one never seemed to have any possession that was really dry. You might have expected constant trouble with the radiolocation equipment, but we didn't have it; it just went on working. On many sites during the second half of 1940, when the Battle of Britain was toward, and the first half of the following year, the guns were constantly active, but so long as radiolocation apparatus received normal care and maintenance attention it seemed to be very little affected by

the vibration. That, I feel, is a real triumph and something more than a credit to those responsible for both design and construction.

**So Simple**

Another remarkable achievement was that the gear was made so simple to operate that it could be handled by intelligent men of the rank and file after a period of training. And not by men only, for by 1941 girls, most of whom had no previous knowledge or experience of electricity and electrical apparatus, were proving themselves to be highly competent radiolocation operators. My first impression of the inside of a radiolocation set was that it was about as complicated a box of tricks as one could want to play with. There are some pretty brain teasers amongst its ingenious circuits and some lovely mazes of wiring to puzzle out. But the actual operation is amazingly simple and complete novices, so long as they are of the right kind, take to it very quickly despite the (at first sight) formidable number of knobs and switches on the panels.

□ □ □

**In the Right Direction**

THE luncheon given recently by the Radio Industry Council to inaugurate the campaign which it is to undertake was a great success.



The new Vortexion 50 watt amplifier is the result of over seven years' development with valves of the 6L6 type. Every part of the circuit has been carefully developed, with the result that 50 watts is obtained after the output transformer at approximately 4% total distortion. Some idea of the efficiency of the output valves can be obtained from the fact that they draw only 60 ma. per pair no load, and 160 ma. full load anode current. Separate rectifiers are employed for anode and screen and a Westinghouse for bias.

The response curve is straight from 200 to 15,000 cycles in the standard model. The low frequency response has been purposely reduced to save damage to the speakers with which it may be used, due to excessive movement of the speech coil.

A tone control is fitted, and the large eight section output transformer is available to match, 15-60-125-250 ohms. These output lines can be matched using all sections of windings, and will deliver the full response to the loud speakers with extremely low overall harmonic distortion.

PRICE (with 807, etc., type valves) £18.10.0

Plus 25% War Increase

MANY HUNDREDS ALREADY IN USE

Supplied only against Government Contracts

**VORTEXION LTD.**  
 257, THE BROADWAY,  
 WIMBLEDON, S. W. 19.  
 Phone: LIBerly 2814



### Random Radiations—

Some 500 of us heard the chairman's account of what the industry has done so far during the war and his forecast of the part it will play when peace returns. The great point is that the industry has got together to let the public know something of its achievements and its intentions. The man-in-the-street may well have imagined that the industry has been asleep since September, 1939. His chief impression of its doings is that it hasn't supplied the new set that he wants and that it has been none too easy to get the old set repaired! He doesn't know, though he will soon when the Council gets into its stride, that the industry is more than two-and-a-half times as big today as it was when war came. Nor does he realise that the seemingly impossible has been accomplished over and over again in keeping pace with the ever-growing and almost insatiable demands of the armed Forces for radiolocation, wireless and electrical gear. Hundreds of acres of new factory space have been built; millions of pounds' worth of precision machinery has been installed, and the industry accomplished all this whilst having to release some of its best men to the Services and to fill its depleted ranks by training novices. The more apparatus the industry supplied to the Navy, the Army and the Air Force, the greater was the demand by them for trained men to operate and maintain it. As it was expanding rapidly all the time, the industry had to train some two-and-a-half novices for every skilled man it lost.

### The Future

This move to let people know what it has achieved and how well prepared it is to supply civilian needs after the war is an excellent one; I hope, too, that its original scope may be enlarged. I've always held that the public needed to be educated in the matter of wireless reception and wireless receivers, and now that the industry is to speak to us with one voice, here is a magnificent opportunity of doing something on these lines. As regards the future, we shall have immediately after the war the receivers that would have appeared in 1939/40. This is sound, for the designs are ready and they can be turned out quickly to meet the enormous demand that will occur. After that there should be interesting developments. I see no reason why the bigger and better set should not ultimately come into its own. Mass production should mean bigger output and smaller cost of valves and other components, and the industry has made immense strides during the

war in mass-production machinery and methods.

□ □ □

### An Interesting Tool

THE Bio Electric Company have sent me one of their Biobas electric soldering irons to try out, and I have made considerable use of it during the week before writing this note. It is not a midget iron suitable for fine work on instruments; it is in fact a light iron (the complete tool weighs about 14 ounces) such as one uses for general wireless jobs, with a bit of screw-driver shape just over a quarter of an inch in width. This iron has several interesting features, the most important of which is the novel and effective method of temperature control. The heater consists of two elements. The main element is made of an alloy which has something like a zero temperature/resistance coefficient; the special alloy used for the ballast element has a high and increasing temperature/resistance coefficient. The two are assembled into a kind of double sandwich between clamping plates. Thus the main element heats the other to approximately its own temperature, causing the total resistance to rise and fall in accordance with the heat conditions; that is, the electrical input is balanced against the heat output. In practice the control works well. I have left the iron idling for half an hour or more and found no noticeable rise beyond the working temperature. In use the temperature remains substantially constant whether the work one is doing calls for the heating of very small surfaces or comparatively large ones. The heater assembly can be withdrawn by removing one screw, and the heater elements changed if need be by removing and reinserting two other screws. Altogether a very satisfactory tool. It will not, I am told, be on the market until some time in March. Meantime I am trying to persuade its makers to produce a midget iron on the same lines.

□ □ □

### A Student's Experience

REFERRING to my notes in last month's *Wireless World* on the training of electrical engineers who wish to specialise in communications, a reader now serving with the R.A.F. sends me an account of his experiences of the course for the B.Eng. degree at one university. Having passed the intermediate, he settled down to work for Part 1 of the final examination, but found that in the course for this telecommunications were completely ignored. How, he asks, would a radio engineer benefit from a deep knowledge of the construction of

cranes, boilers, heat engines, chimneys, dams and roof trusses? It might be useful to him on rare occasions to know something of such things; but surely it is a work of supererogation to devote the time and energy needed to study them in detail. There was, he found, to be no real work in radio until the last year of the course. In disgust he turned in his student's exemption from military service and joined the Air Force. Really, I'm not surprised. This kind of thing must be most galling to a keen youngster. It is high time that the authorities of some universities at any rate realised the great and growing importance of radio—to say nothing of the vastness of the subject—and put their houses in order accordingly.

□ □ □

### A Singing Lamp

THE note by K. G. B. (February *Wireless World*) on the failure of an electric lamp was particularly interesting to me, for some time ago I came across a "singing" lamp that caused a perfect uproar of noise from the loudspeaker of a set in the same room. This lamp must have had a broken filament for some days. Here is what happened. I was spending the evening with some friends and at nine o'clock the set was switched on for the news. As its heaters warmed up horrible noises began to issue from the loudspeaker. The set, I was told, had been like that for a day or two; they had given up using it except for the news, which was just intelligible above the din. Then one member of the family said that she had tried it early that afternoon and found it absolutely as it should be. That gave me a clue: whilst the news was coming in I switched off the only light in use in the room, a pendant 100-watt bulb. Reception immediately became normal the din starting again as soon as the lamp was switched on. There was no noticeable flickering of the light, but a distinct low singing noise could be heard when one's ear was near the lamp. A replacement was fitted and I asked to be allowed to take the faulty one home for examination.

### A Curious Break

When I came to have a look at it in daylight, I found a rather unusual state of affairs inside the bulb. It was an old lamp with a tungsten filament strung zig-zag between spoke-like supporting arms, each with a hook at its end. At first I couldn't find the break, but I spotted it at last with the help of a reading glass—luckily it was a clear bulb. The filament had given way at the very bottom of one of the

downward "zags" and the main part had either jammed itself in or become welded to the hook. The broken end was standing off only a tiny fraction of an inch from the hook. When the lamp was put into a holder and switched on the loose end of the filament could be seen vibrating. It was, I suppose, owing to the rapidity of the vibrations that there was no obvious flickering of the light. The broken end would be physically attracted to the hook as current increased in either direction and released at the minima. The most interesting and unusual point was that the lamp continued to function for so long and survived so many switchings on and off. Years ago, when that method of filament suspension was, if not the only method in use, at any rate the most usual, one could sometimes effect a repair when a filament broke between two hooks. You put the bulb on a table and turned it till the break was uppermost. A few sharp taps on the glass might, if you were lucky, make the broken ends overlap and when current was subsequently passed through the filament they would often stay put for some little time.

□ □ □

**Nae Bother at A'!**

WHY, I wonder, should the Saltire Society of Scotland be so anxious that Scots should have complete control of their own programmes? One of their suggestions is that the proceeds of all the Scots receiving licences should be handed over to a Caledonian Broadcasting Corporation, which would then assume entire responsibility. Well, the licence fees collected in Scotland amount to only about £400,000, and I shouldn't have thought that that would go very far. To the best of my recollection the peacetime Scottish Regional programme hadn't much of the Sassenach about it. But if they feel that they'd like to make the Scottish National really a Scottish National, why not say "It's nae bother, nae bother at a'" and hand it over? That would at any rate solve the problems of those Gaelic "hours" and news bulletins, which (if one dare breathe it!) were found rather a nuisance by southrons. There'd need be no need to tie the C.B.C. down to the £400,000; we could supply them gratis with any of our "piped" programmes that they liked to take.

**GOODS FOR EXPORT**

The fact that goods made of raw materials in short supply owing to war conditions are advertised in this journal should not be taken as an indication that they are necessarily available for export.

*It's the hidden details that count*

140  
Dtypes  
in  
production

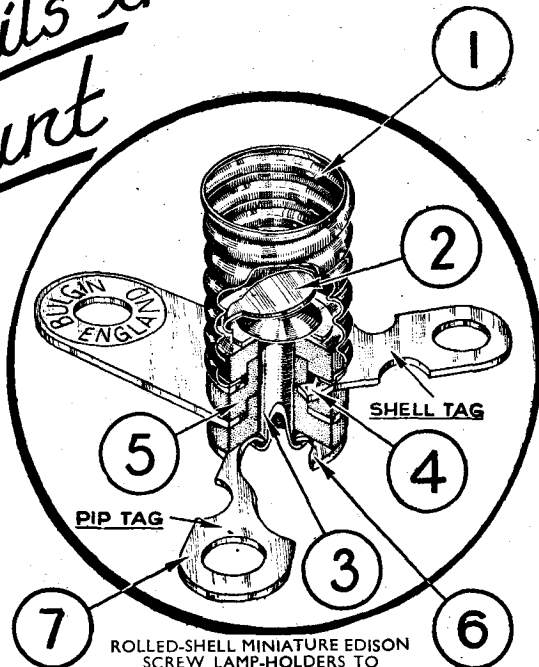

ROLLED-SHELL MINIATURE EDISON SCREW LAMP-HOLDERS TO B.S. 98/E.10.

- 1 — Threaded shell with dimensions and details to B.S. 98—10 mm. "MES"; silver-plated finish.
- 2 — Central "pip"-contact of spring phosphor-bronze to ensure good contact; silver-plated.
- 3 — Central rivet of solid steel ensuring permanently tight and positioned assembly.
- 4 — Locking teeth on "shell"-contact solder-tag, ensuring contact and preventing unintended rotation.
- 5 — Stepped insulant-washers preventing short-circuit and permitting comparatively high-voltage working conditions.
- 6 — Toothed solder-tag locks to rivet-turnover, fixing position and ensuring contact to "pip"-contact.
- 7 — Dual-purpose soldering tags coated pure tin and accepting "threaded" or "wound" wiring; fixing bracket, normally "dead," may contact with shell and replace the "shell-tag."

**THE CHOICE OF CRITICS**



**A. F. BULGIN & CO. LTD., BYE PASS RD., BARKING, ESSEX**

RIPpleway 3474 (5 lines)

(The name "BULGIN" is registered Trade Mark)

# RECENT INVENTIONS

## RADIO BEACONS

**H**ORizontally polarised waves are generally used for marking out a short-wave navigational course from a beacon station, because they are less subject than vertically polarised waves to be re-radiated from the ground, or from the conductors normally found in the vicinity of an airdrome. This in turn makes it easier to give an unambiguous indication to the pilot.

The drawing shows an aerial system of this kind designed to provide four converging routes. Two pairs of antennae A, B and C, D, elevated above ground, are arranged at the four corners of a square, the side of which is approximately half the working wavelength. Each unit consists, as shown separately, of two horizontal crossed dipoles 1, 3 and 2, 4, the conductors of each pair being energised in phase opposition. The overall length of a radiator is half a wavelength, but the outer ends are bent over, so that radia-

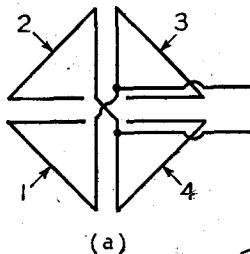

Beacon aerial system.

tion is effectively concentrated along the sides of each of the smaller squares, the usual "end-effect" of vertical polarisation being thus minimised.

One pair of units A, B is connected to the RF source in alternation with the other pair C, D through a switch (not shown) which is operated in the usual A-N sequence so as to apply interlocking signals to the two overlapping beams. A metal sheet S screens the aerials from the ground so as to prevent re-radiation from that quarter.

*Standard Telephones and Cables, Ltd. (assignees of A. Alford). Convention date (U.S.A.) October 19th, 1939. No. 563075.*

## APPROACH PATH BEAMS

**W**HEN waves of the order of three metres or less are used at an airfield for marking out an approach path, the effect of re-radiation from the steel and other metal work in the vicinity of the transmitter becomes pronounced and troublesome. The reflected waves are superposed on the

## A Selection of the More Interesting Radio Developments

direct energy of the overlapping beams and so produce undesired "field-patterns," which tend to blur the true straight-line path, and to create local "false" paths.

This so-called "scalping" effect is avoided, according to the invention, by deliberately wobbling the carrier-wave frequency of the beacon over a range of, say, one per cent. At any given point in space, the phases of the reflected waves will then vary differently from those of the direct beams, according to the individual space paths, but the instruments on the aircraft will respond only to the "average" pattern produced during each complete wobble. They will therefore correctly indicate the approach path marked out by the original beams.

*Standard Telephones and Cables, Ltd. (assignees of A. Alford). Convention date (U.S.A.) October 11th, 1939. No. 563076.*

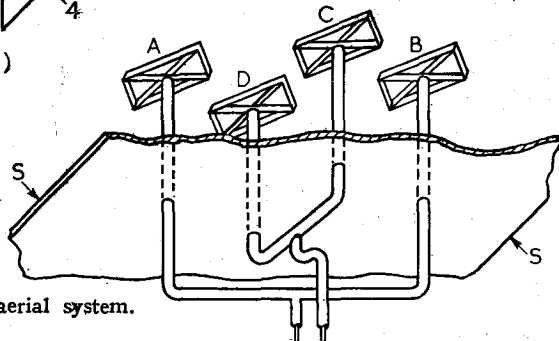

## PIEZOELECTRIC CRYSTALS

**T**O minimise the effect of mechanical vibration on a crystal oscillator, when used, say, on an aircraft, the element is generally held under compression between nodal points, where the clamping produces the least possible damping. In practice, it is found that mechanical shocks tend to make the gripping points slip out of position on the smooth surface of the crystal, and so give rise to sudden jumps in the operating frequency. Any such movement is also liable to scratch the thin metal film forming the electrode.

By contrast, it is now proposed to hold the crystal under a constant tension or stretching force. A V-cut crystal, for instance, is gripped between the flat lower face and a peripheral lip or rim on the dished upper face, by a pair of suitably shaped jaws, each carried by a terminal spring. In the case of a flat crystal, the bent end of each holding-spring is hooked into a hole or recess formed on opposite

sides of the oscillator. To prevent twisting or turning movements, two separate grips may be provided along one side of the crystal.

*Marconi's Wireless Telegraph Co., Ltd. (assignees of S. A. Bokovy). Convention date (U.S.A.) July 5th, 1941. No. 563139.*

## MICROPHONE "BACKGROUND" NOISE

**T**O ensure clarity, when broadcasting directly from a political meeting or other public gathering, the general background of noise should preferably be excluded from the line. One suggested way of securing this result is to use two separate microphones, connected in opposition, and spaced apart so that the more distant undesired noises are balanced out, whilst voice of a nearby speaker is not.

The present invention is based on the assumption that the following features are essential to the successful operation of such a system: (a) The two microphones should be separated by a distance not exceeding a quarter of the wavelength of the highest frequency it is required to eliminate; approximately three-quarters of an inch is specified. (b) Both microphones should be non-directional. (c) Only sound apertures should be available, one for each microphone.

In one described arrangement, the two microphones are mounted on the inner faces of a baseplate which is bent into a wide-angled "vee," so that the voice of the speaker is mainly directed against only one of the pair.

*F. C. Beekly. Convention date (U.S.A.) December 26th, 1941. No. 563595.*

## MAGNETIC DUST CORES

**T**HE powdered-iron cores used for RF inductances are so brittle that they are liable to crack or break, either when being wound, or during the final heat treatment, when replacement is costly.

According to the invention, the cores are strengthened by including reinforcing strips of non-magnetic material in the course of manufacture. For instance, the core for a toroidal winding is moulded in two "split" halves, each circular in plan and semicircular in cross section. A ring-shaped strip of whalebone fibre, 20 to 40 mils thick, is cemented to the flat face of each half, and the two halves are then cemented together, strip to strip, to form the complete reinforced core. This is baked hard to dry out the cement, before being taped and varnished.

*Automatic Telephone and Electric Co., Ltd.; J. Bylewski; and A. Davidson. Application date, April 1st, 1943. No. 564621.*

The British abstracts published here are prepared with the permission of the Controller of H.M. Stationery Office, from specifications obtainable at the Patent Office, 25, Southampton Buildings, London, W.C.2, price 1/- each.